

# Grillo

AGRIGARDEN MACHINES



## FK 700

## Hydrostatic Mower

OPERATOR'S MANUAL

EN



02621.2025.09

## TABLE OF CONTENTS

<b>1. Introduction</b> .....	<b>3</b>	<b>16. Troubleshooting guide</b> .....	<b>26</b>
<b>2. Description and intended use</b> .....	<b>3</b>	<b>17. Maintenance schedule</b> .....	<b>28</b>
<b>3. Safety decals</b> .....	<b>4</b>	<b>18. Lubrication chart</b> .....	<b>28</b>
<b>4. General safety rules</b> .....	<b>5</b>	<b>19. Storage and prolonged inactivity</b> .....	<b>29</b>
<b>5. General warnings to keep in mind</b> .....	<b>7</b>	<b>20. Towing the machine with the engine off</b> .....	<b>29</b>
<b>6. Identification of use decals</b> .....	<b>8</b>	<b>21. Technical assistance service</b> .....	<b>29</b>
<b>7. Identification of machine controls and functions</b> .....	<b>9</b>	21.1 Assistance .....	29
<b>8. Identification of flail mower components</b> .....	<b>10</b>	21.2 Identification data .....	29
<b>9. Technical specifications</b> .....	<b>11</b>	21.3 Spare parts .....	29
<b>10. Operating instructions</b> .....	<b>12</b>	21.4 Warranty .....	29
10.1 Checks to be carried out before starting the engine .....	12	21.5 How to order spare parts .....	29
10.2 Starting the engine .....	12	<b>22. Transport warnings</b> .....	<b>30</b>
10.3 Starting the machine.....	12	<b>23. Disposal</b> .....	<b>30</b>
10.4 Work conclusion .....	13	<b>Declaration of Conformity</b> .....	<b>31</b>
10.5 Ordinary machine cleaning .....	13		
10.6 Useful rules for correct use.....	13		
10.7 Sloping terrain and differential .....	14		
<b>11. Safety devices</b> .....	<b>14</b>		
11.1 Electronic safety .....	14		
11.2 Parking brake .....	14		
11.3 Roll-Bar .....	14		
<b>12. Ordinary adjustments</b> .....	<b>15</b>		
12.1 Seat adjustment.....	15		
12.2 Cutting height adjustment.....	16		
12.3 Gear selection .....	16		
<b>13. Extraordinary adjustments</b> .....	<b>17</b>		
13.1 Adjusting the parking brake .....	17		
13.2 Adjusting the PTO drive belts .....	17		
13.3 Adjusting the flail mower belts .....	17		
<b>14. Ordinary maintenance and lubrication</b> .....	<b>18</b>		
14.1 Lubrication .....	18		
14.2 Engine maintenance .....	18		
14.3 Battery maintenance.....	19		
14.4 Flail mower maintenance.....	20		
<b>15. Extraordinary maintenance</b> .....	<b>20</b>		
15.1 Fuel system maintenance.....	20		
15.2 Cooling system maintenance .....	21		
15.3 Hydraulic system maintenance.....	21		
15.4 Flail mower maintenance and complete disassembly ...	22		
15.5 Driving belt maintenance .....	22		
15.6 Electrical system maintenance .....	24		
15.7 Battery replacement .....	25		
15.8 Wheel maintenance.....	25		

Translation of the original manual.  
All information, illustrations and technical specifications in this manual are based on the latest information available at the time of publication.  
Subject to change without prior notice.

## 1. INTRODUCTION

Dear Customer,

we thank you for the trust and preference you have placed in our Grillo FK 700 and we are confident that the use of your new machine will fully meet your requirements.

For optimal use and maintenance over time, please carefully read and follow the instructions in this booklet; this will enable you to obtain the best results and safeguard your purchase.

Please keep this manual, which should always accompany the machine as an integral part of it.

**Reading the operator's manual is very important.**

## 2. DESCRIPTION AND INTENDED USE

The Grillo FK 700 is a ride-on hydrostatic mower designed for shredding and cutting grass.

Any other use is considered as improper use.

This machine must only be used by personnel who are familiar with its specific features, safety regulations and all that concerns accident prevention.

Any improper use of the machine will invalidate the warranty and relieve the manufacturer of all responsibility; any risk resulting from improper use will be borne by the user.

Maintenance and repair of the machine must be carried out by qualified personnel following the procedures specified by the manufacturer. Any alteration or tampering will invalidate the warranty and relieve the manufacturer of all responsibility for damage or accidents.

### MARKINGS IN THE MANUAL

This manual contains warnings highlighted in bold and marked with these symbols:



#### **CAUTION**

**This symbol and the text that follows it contain information that highlights possible, even very serious, risks to the safety of the operator and anyone working on the machine if they do not consider the written information and procedures.**



#### **IMPORTANT**

**This heading informs the operator of actions or conditions that could damage the machine.**

Read these messages carefully to avoid injury or damage to the machine.

The retailer is responsible for inspecting the machine before delivery and for completing the inspection form "PRE-DELIVERY INSPECTION".

On this occasion the retailer will provide the customer with all the information necessary to use the machine.

The customer will receive the machine in optimum condition.

### 3. SAFETY DECALS

VIEW FROM THE DRIVING SEAT

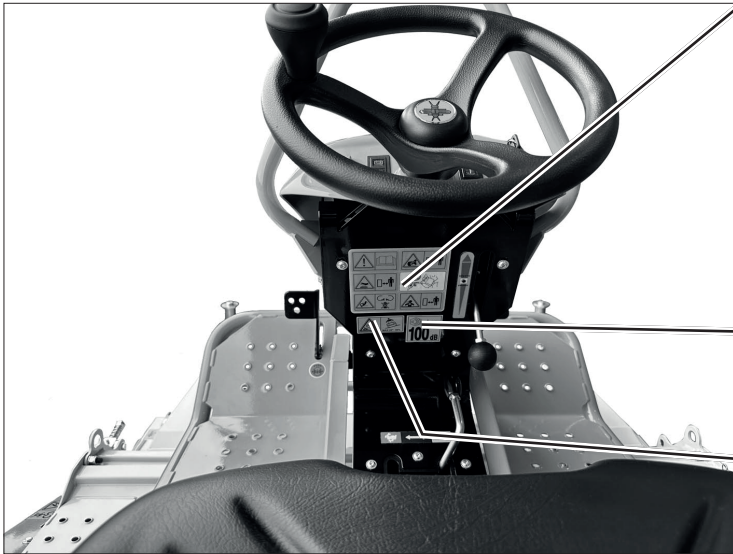

Consult the manual

Danger of burns

Danger of injury caused by transmission parts



Danger of bursting

Danger of fire

Danger of gas inhalation



Sound power level



Danger of machine overturning

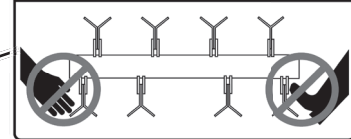

Danger of injury from sharp knives



Risk of injury caused by the rotation of the cardan joint



Danger of injury caused by transmission parts



LEFT-HAND SIDE OF THE FLAIL MOWER

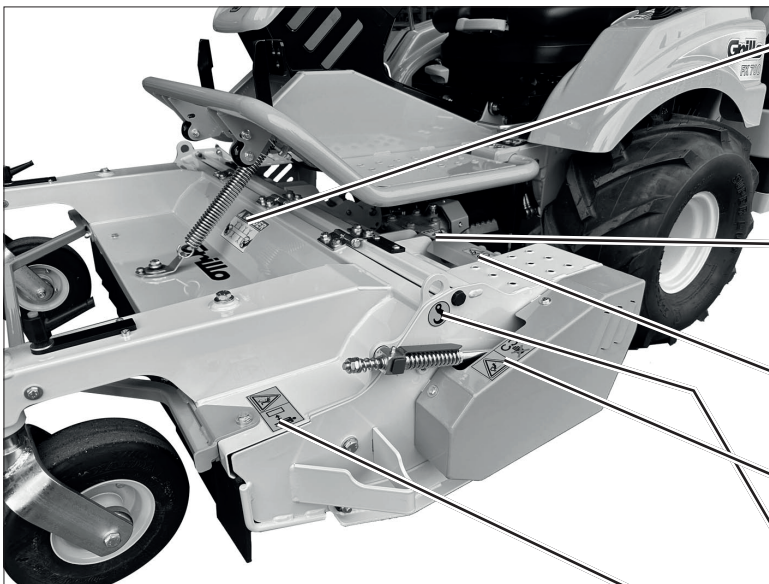

RIGHT-HAND SIDE OF THE FLAIL MOWER

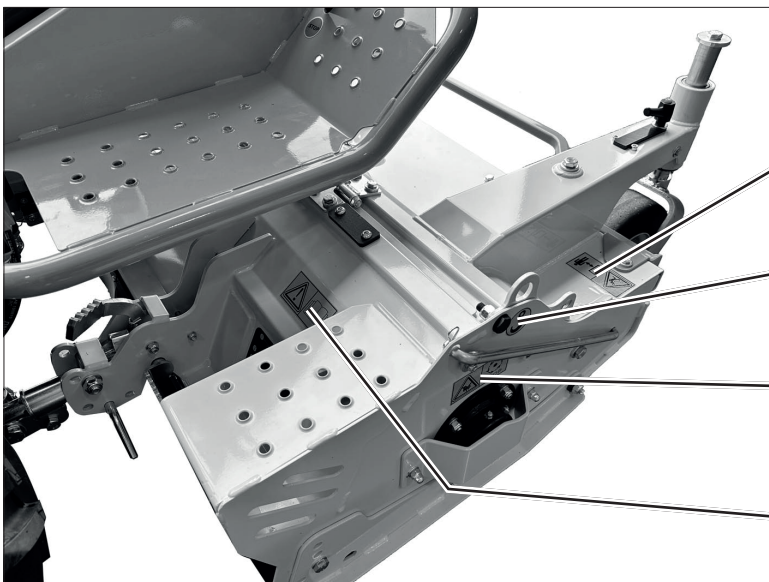

Danger of objects thrown by the rotation of the knives



Lifting points



Danger of injury from sharp knives



Consult the manual

## 4. GENERAL SAFETY RULES

### ACCIDENT PREVENTION RULES

On the machine and in this manual there are warnings and indications accompanied by this symbol:



it indicates the presence of a potential hazard for which particular caution should be taken for your own safety and for the safety of others who may be within the operating range of the machine.

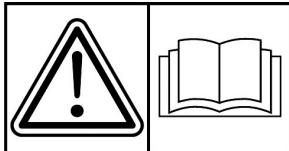

All accident prevention rules in this manual are important and must be observed. Always keep the manual handy and read it carefully to learn how to use the machine safely. Do not allow anyone to use the machine without having received comprehensive instructions.

### EXPLANATION OF WARNING DECALS

#### Danger of objects thrown by the rotation of the knives

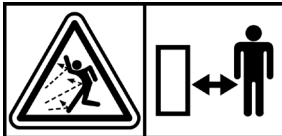

Do not work with the flail mower on gravel or foreign bodies that can be thrown by the knives, making them very dangerous. Keep people at least 15 m away when the machine is running.

#### Danger of injury from sharp knives



Do not put hands or feet under or in the flail mower when the engine is running. Switch off the engine, disengage the PTO and make sure the rotor is stopped before carrying out maintenance or cleaning operations on the flail mower.

#### Risk of injury caused by the rotation of the cardan joint



Do not touch the cardan joint while it is rotating, this can cause serious injury. Do not carry out maintenance while the engine is running.

#### Danger of injury caused by transmission parts

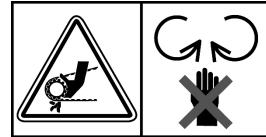

When the engine is running, never touch pulleys or belts, do not carry out maintenance and keep hands away from the designated area.

#### Danger of machine overturning



Do not use the machine on slippery ground or on slopes with a gradient greater than 20° (36%).

#### Danger of bursting

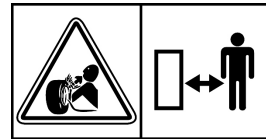

Rim separation or tyre bursting can cause serious injury or even death. Be sure to maintain tyre pressure at the levels recommended in this manual, excessive pressure can cause the tyre to burst. If a tyre is damaged or cut, do not use it, it could burst. To replace or repair it, contact a specialised centre.

#### Danger of burns

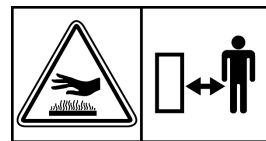

Take particular care not to come into contact with hot engine parts.

#### Danger of gas inhalation

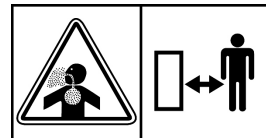

Exhaust fumes can cause serious damage to health or death. If it is necessary to start the engine in an enclosed space, use an extension piece to the exhaust pipe to blow out the smoke. Work in a well ventilated area.

#### Danger of fire



Handle fuel with care as it is highly flammable; do not refuel while smoking, near open flames or sparks, when the engine is running.

## Lifting points



Use the points indicated for lifting the flail mower.

## Danger of explosion



Keep the battery away from flames or sparks. The gases that may escape are highly explosive.

## Danger from acid



The acid contained in the battery is highly toxic if inhaled. It can also cause skin burns, puncture clothing and cause blindness if in contact with the eyes.

## PERSONAL PROTECTION EQUIPMENT



Before using the machine the appropriate personal protection equipment must be worn: body protection, protective gloves, safety footwear, hearing protection, goggles.

## ROLL-BAR



**⚠ CAUTION:** the roll-bar safety device must always be kept raised and tightened during work. Use the seat belt as well.

## 5. GENERAL WARNINGS TO KEEP IN MIND

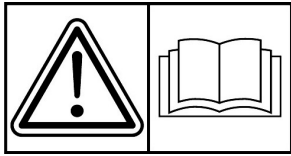

**WARNING:** Read carefully before operating the machine.

**Caution is the main requirement in accident prevention! Carefully read the following warnings when using the machine, even before starting work. Improper use can be dangerous. Observe the following precautions:**

- Read this manual completely before starting and running the machine;
- Before handing the machine over to other people, make them aware of the safety rules and how to use the machine;
- Pay particular attention to the safety decals on the machine;
- Before starting work, always wear appropriate work wear, long trousers, gloves, safety shoes and goggles;
- The use of hearing protection equipment is recommended when using the machine continuously. Use earplugs or earmuffs that comply with current regulations.

### SAFETY IN THE WORKING ENVIRONMENT

- Before switching on the machine, check that there are no animals or people nearby, especially children; the minimum distance is 15 m;
- Before reversing, check that there are no people or obstacles behind the machine;
- Check the ground before mowing, that there are no stones, sticks or foreign bodies, which could be thrown away dangerously;
- Be very careful when working on land with sandy areas or gravel driveways. Sand and gravel can be thrown violently by the rotor, making them very dangerous;
- Be careful when working near a road;
- Do not operate near ditches or embankments which may collapse under the weight of the machine, especially if the ground surface is uneven or wet.

### DRIVING AND BEHAVIOURAL SAFETY

- Keep ignition keys out of the reach of children;
- Do not allow passengers in the machine;
- Children under 16 years of age must not use the machine;
- Do not use the machine when fatigued or under the influence of alcohol, drugs or medications that impair the physical or cognitive abilities of the operator;
- Be careful while driving and avoid abrupt turns, especially at maximum speed;
- Drive at low speed on uneven ground;
- Slow down on slopes and descents, and always steer slowly;
- Only work in sunlight or with good artificial light;
- Do not leave the machine on a slope;
- Before getting off the machine, switch off the PTO, lower the flail mower if lifted, switch off the engine, apply the parking brake and remove the ignition key.

### FURTHER SAFETY MEASURES

- If you hit a foreign object, disengage the PTO, stop the engine, remove the ignition key and inspect the rotor and knives for damage. If damaged, repair them before putting the flail mower back into operation;
- If the machine begins to vibrate abnormally after a knock, immediately carry out a general check to identify the reason for the anomaly. If necessary, request the assistance of an authorised Grillo workshop;
- The rotation of the flail rotor is very dangerous, never put hands or feet under the rotor;
- Before checking, adjusting, repairing or simply cleaning the machine, disengage the PTO and switch off the engine;
- Do not place any weight on the seat, as this could deactivate the ignition safety device;
- Do not tamper with or disable the safety devices;
- Do not change the engine settings, especially the maximum revs;
- Do not have anyone check the machine while you are driving with the engine running;
- Do not move the machine without the flail mower, the machine could become unbalanced and driving could be dangerous.

### FUEL AND FIRE HAZARD

- Only refuel outdoors, always switch off the engine, stay away from sparks or flames, do not smoke! Securely replace tank and fuel container caps;
- Avoid fuel spills. After filling the tank clean up any spillage on the machine before starting the engine;
- Store fuel in containers specifically designed for this purpose;
- If it is necessary to empty the tank, do so outdoors or in a ventilated area;
- Caution! To reduce the risk of fire, always keep the engine compartment, muffler, exhaust manifold, battery, fuel tank area and fuel line clean and free from grass, leaves and dust;
- Do not store the machine in buildings where the fuel vapours could reach flames and sparks;
- Allow the engine to cool down before storing the machine in an enclosed area.

### SAFE REPLACEMENTS

- Deformed or damaged knives must always be replaced, never repaired;
- Replace the muffler if it is worn or damaged;
- The transmission belts are manufactured especially for this machine, do not replace them with other compatible ones, use genuine belts;
- Always use genuine Grillo spare parts and accessories.

## 6. IDENTIFICATION OF USE DECALS

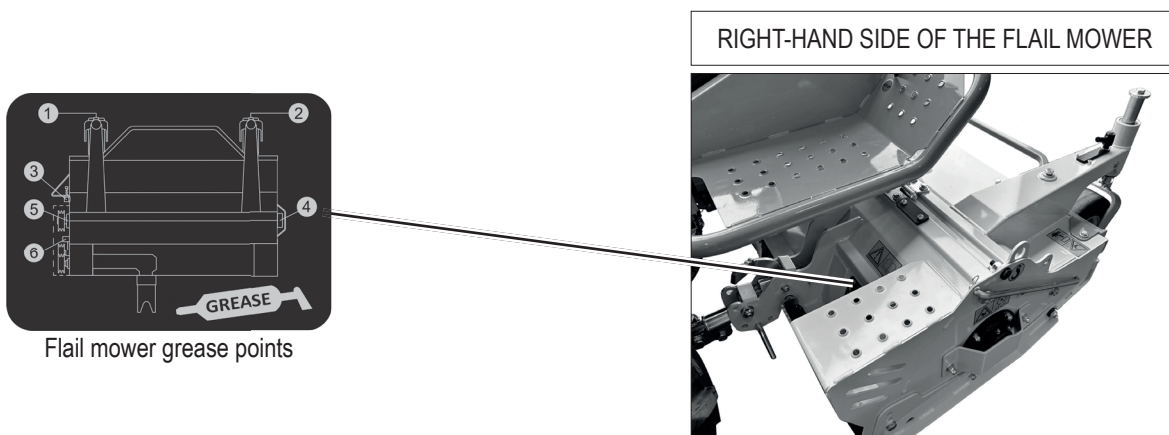
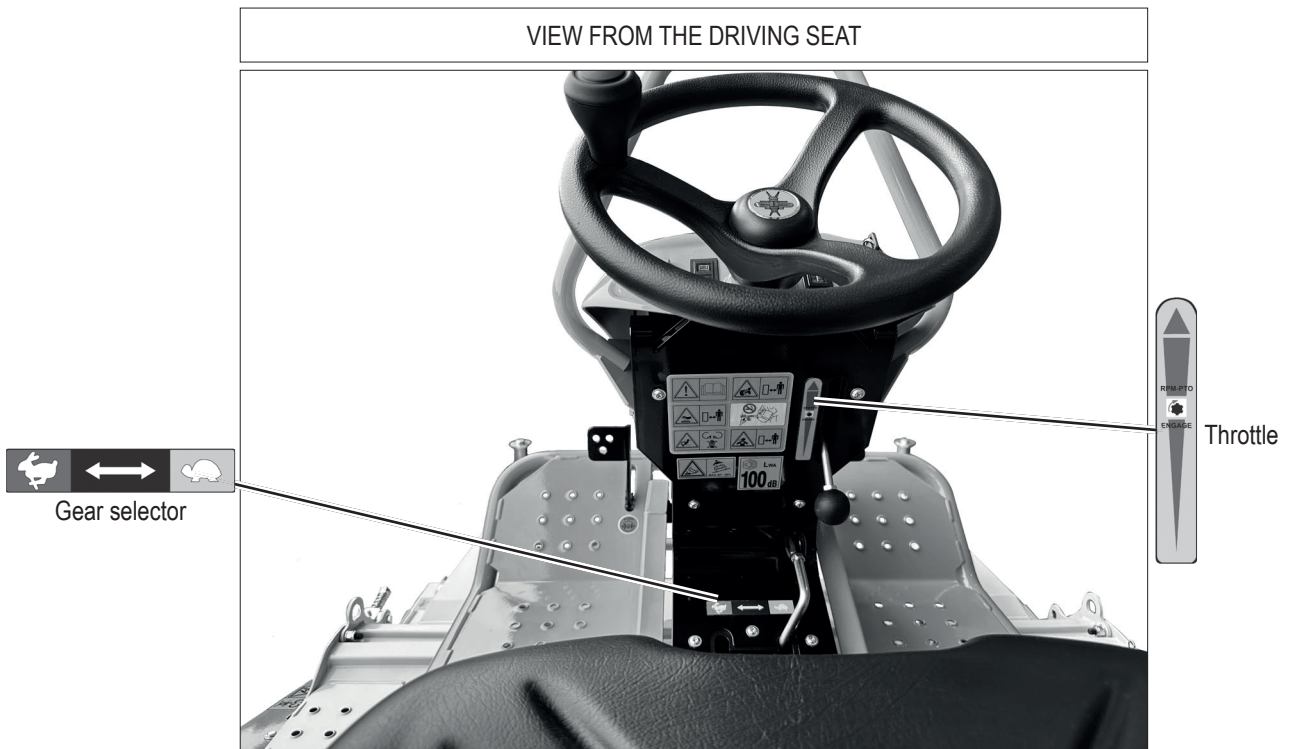
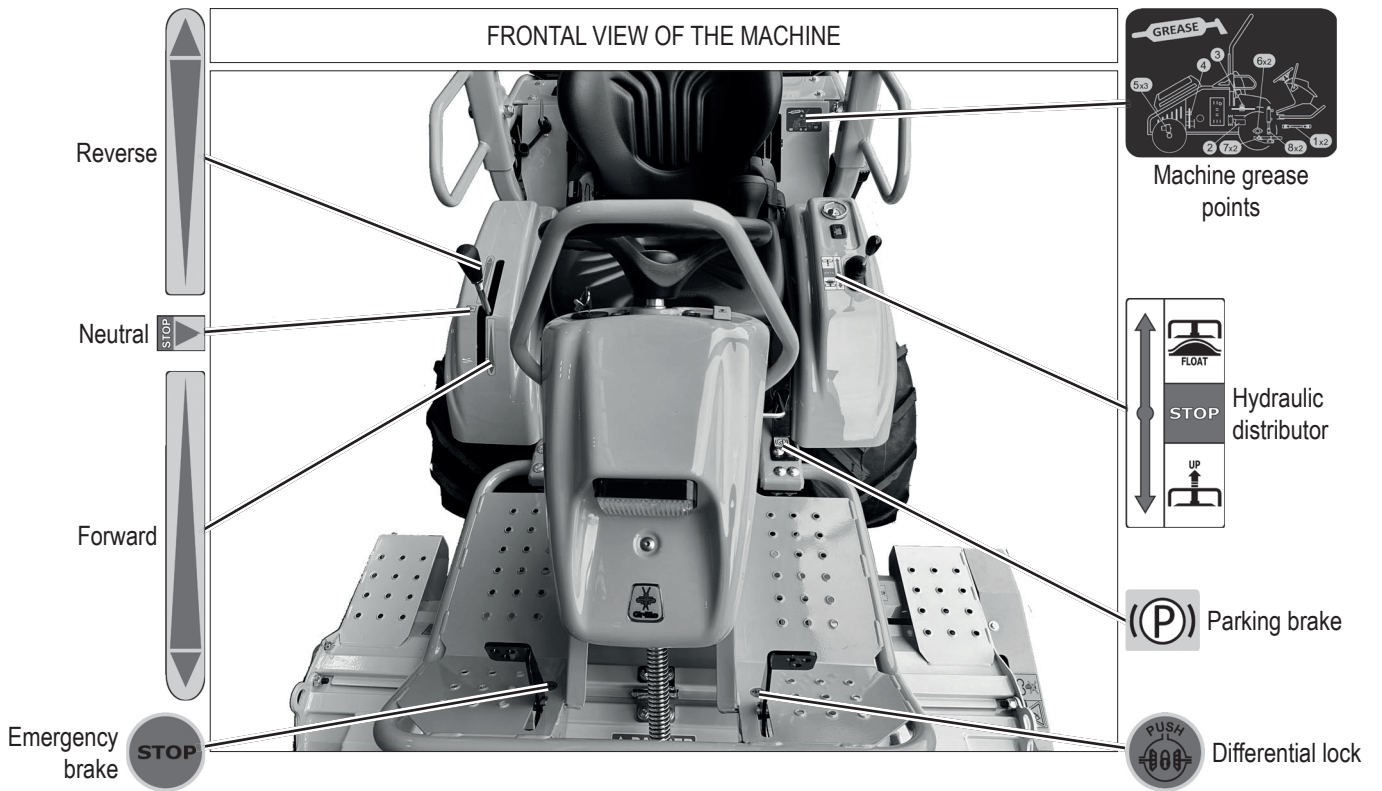

## 7. IDENTIFICATION OF MACHINE CONTROLS AND FUNCTIONS

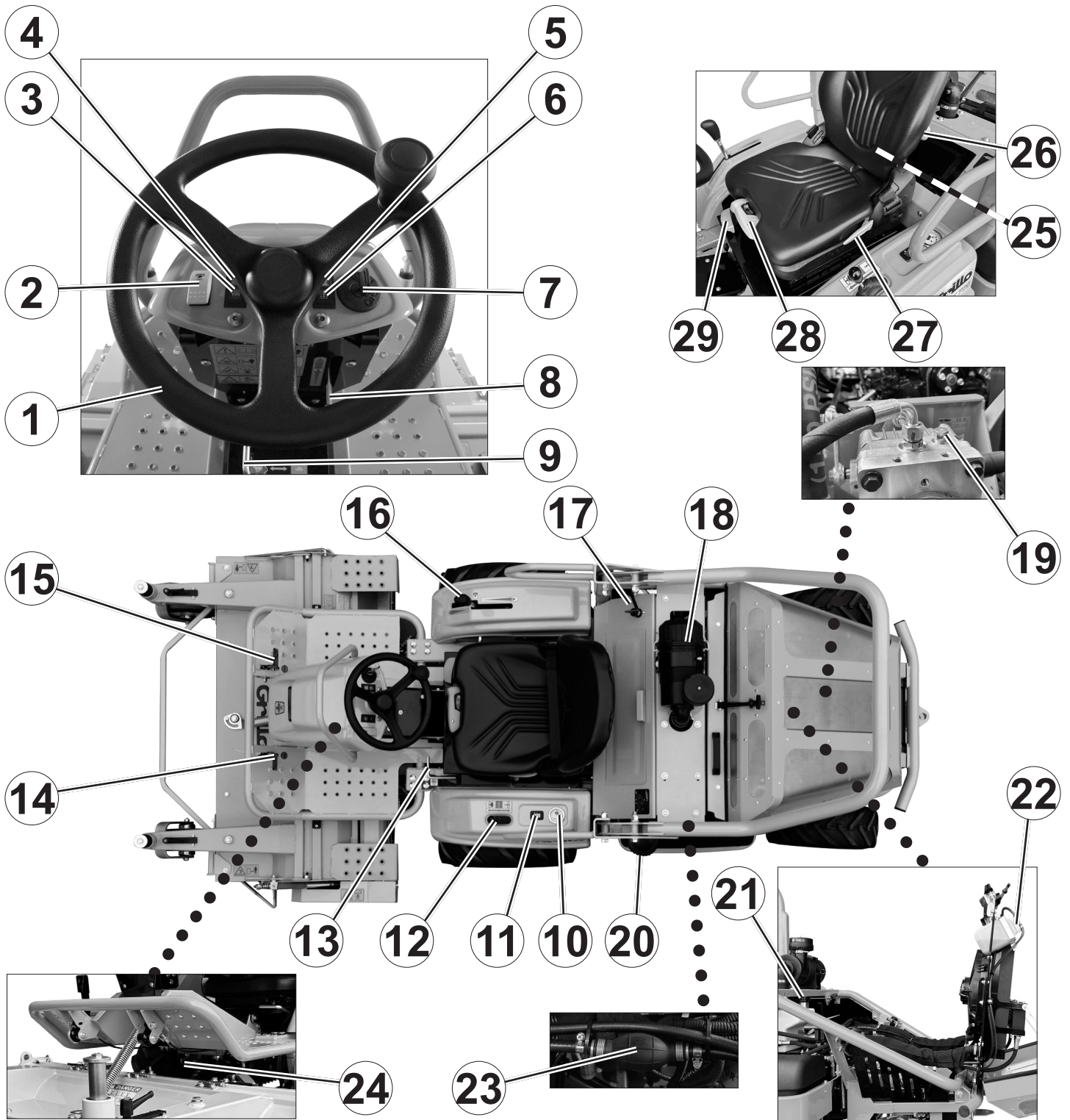

- |                                     |                                      |
|-------------------------------------|--------------------------------------|
| 1. STEERING WHEEL                   | 16. DRIVE LEVER                      |
| 2. PTO BUTTON                       | 17. BATTERY CUT-OFF SWITCH           |
| 3. ENGINE OIL WARNING LIGHT         | 18. AIR FILTER                       |
| 4. BATTERY WARNING LIGHT            | 19. TRACTION BYPASS SCREW            |
| 5. ENGINE PREHEATING WARNING LIGHT  | 20. FUEL TANK CAP                    |
| 6. ENGINE TEMPERATURE WARNING LIGHT | 21. HYDRAULIC OIL TANK CAP           |
| 7. IGNITION KEY                     | 22. COOLANT FLUID RESERVOIR CAP      |
| 8. THROTTLE                         | 23. DIESEL HAND PUMP                 |
| 9. GEAR SELECTOR LEVER              | 24. FOOTPLATE LATCH                  |
| 10. FUEL LEVEL INDICATOR            | 25. SEAT UNLATCH LEVER               |
| 11. HOUR METER                      | 26. LUMBAR SUPPORT ADJUSTMENT KNOB   |
| 12. HYDRAULIC DISTRIBUTOR LEVER     | 27. BACKREST TILT ADJUSTMENT LEVER   |
| 13. PARKING BRAKE LEVER             | 28. SEAT SPRING ADJUSTMENT LEVER     |
| 14. DIFFERENTIAL LOCK PEDAL         | 29. SEAT HORIZONTAL ADJUSTMENT LEVER |
| 15. EMERGENCY BRAKE PEDAL           |                                      |

## 8. IDENTIFICATION OF FLAIL MOWER COMPONENTS

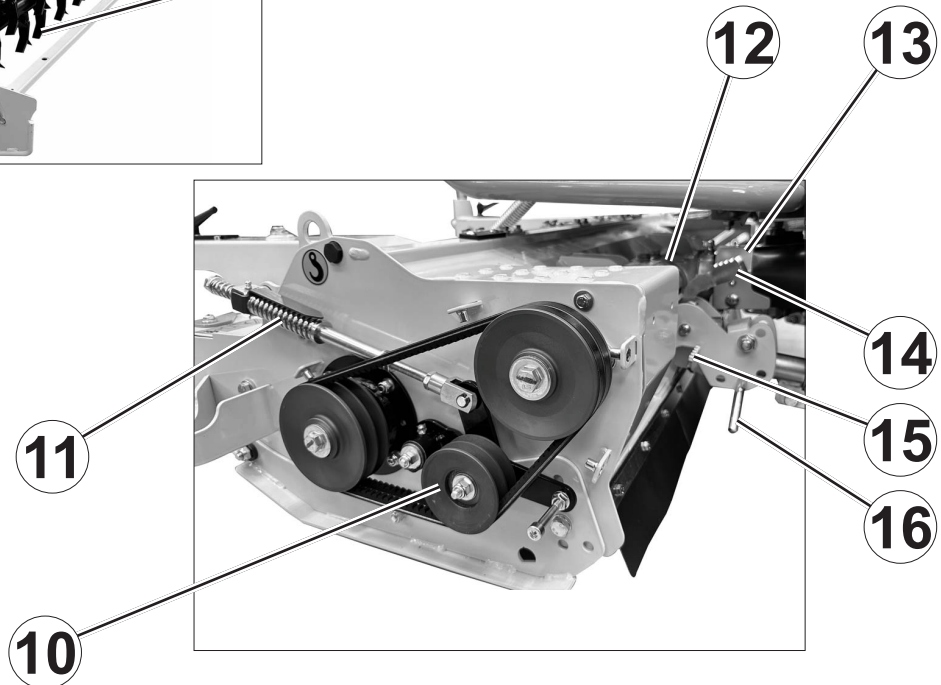
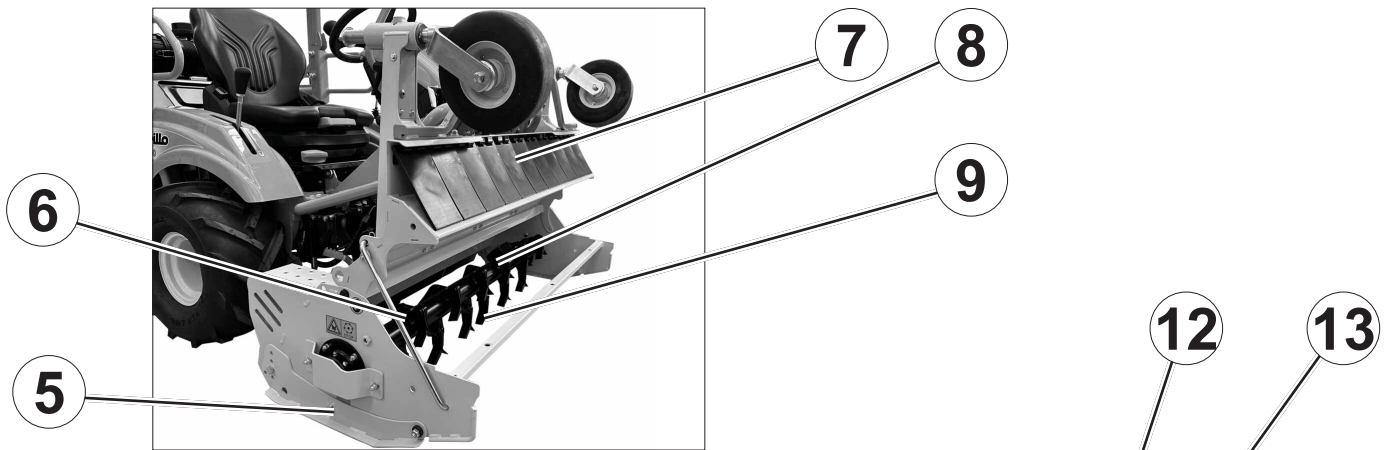
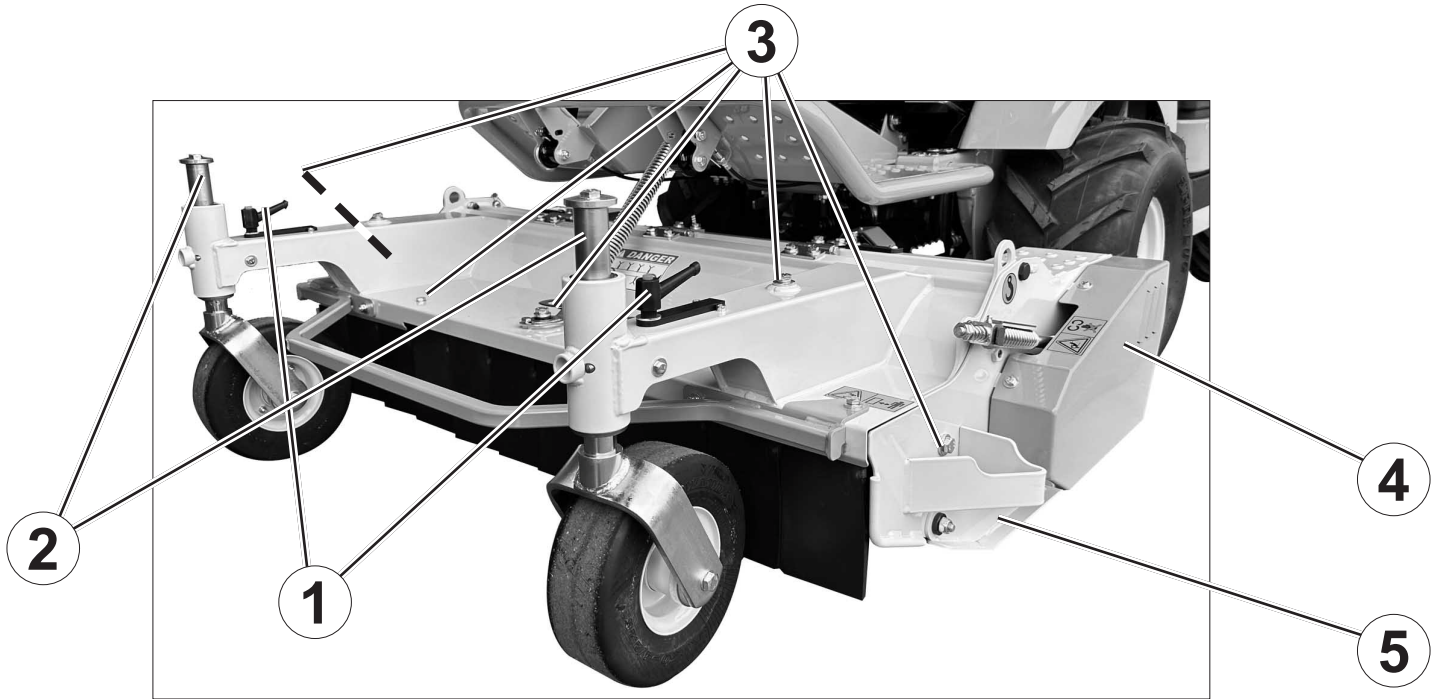

1. CUTTING HEIGHT LOCKING LEVERS
2. HEIGHT-ADJUSTABLE WHEEL FORK
3. FLAIL BODY LOCKING SCREWS (X 5)
4. TRANSMISSION COVER
5. LOWER SKID
6. SUPPORT ROD
7. FLAPS
8. CUTTING ROTOR

9. KNIVES
10. BELT TENSIONER IDLER
11. BELT TENSIONER SPRING
12. GEARBOX
13. CARDAN SHAFT COVER
14. FLAIL MOWER UNCOUPLING PEDAL
15. FLAIL MOWER EJECTION PEDAL
16. LOCKING PIN WITH COTTER PIN

## 9. TECHNICAL SPECIFICATIONS

**MODEL:** FK700, hydrostatic mower with front flail mower.

**ENGINE:** KUBOTA D722-E4B-EU-Y2, Diesel EPA/CARB Tier 4, EU Stage V, ECE R120, 722 cc, 13.2 kW (18 HP) at 3200 rpm, 3 cylinders, liquid cooled, with electric fan and automatic radiator cleaning device.

**FUEL TANK CAPACITY:** 31 litres.

**HYDRAULIC OIL CIRCUIT CAPACITY:** 6.5 litres.

**STARTER:** electric 12 V.

**DRIVE:** hydrostatic 2-wheel drive with cascade reduction gear, parking brake and differential.

**DIFFERENTIAL LOCK:** mechanical with pedal control.

**DRIVING SYSTEM:** steering wheel with hydraulic drive, with lever operated forward and reverse gears.

**PTO:** electromagnetic, with integrated brake.

**SPEED:** continuously variable

- slow speed: 0-8 km/h;

- fast speed: 0-15 km/h.

**WHEELS:** front 20x10.50-8 TRACTOR; rear 16x6.50-8 TRACTOR.

**SEAT:** sprung with adjustable slides and seat belt included.

**STEERING WHEEL:** mounted on steering column, with knob.

**TURNING RADIUS:** 37 cm.

**AUTOMATIC FEATURES:** radiator cleaning.

**BRAKE:** disc parking brake on gearbox.

**CUTTING SYSTEM:** rotor with three rows of knives.

**CUTTING HEIGHT:** from 0 to 10 cm with mechanical quick adjustment.

**CUTTING WIDTH:** 115 cm.

### ATTACHMENTS:

- Scarifying knife kit;
- Grass blade kit;
- Rear roll kit;
- Garden wheels.

### SIZE (with flail mower, fig. 1):

- Length (A): 283 cm;
- Width (B): 134 cm;
- Height: 139 cm (C: roll-bar lowered) - 182 cm (D: roll-bar raised);
- Ground clearance (E): 15 cm;
- Wheelbase (F): 118 cm.

### WEIGHT:

- Without flail mower: 495 kg;
- With flail mower: 615 kg.

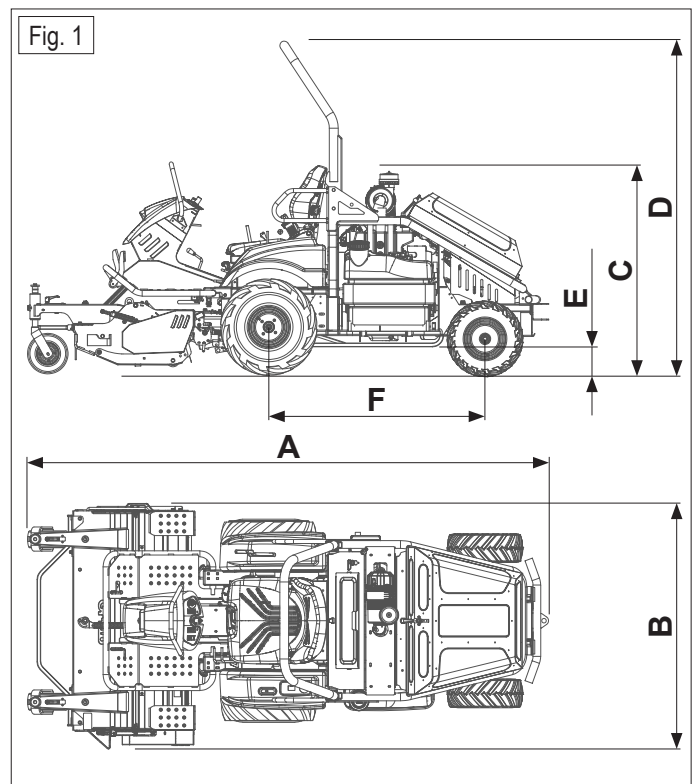

## 10. OPERATING INSTRUCTIONS

### 10.1 CHECKS TO BE CARRIED OUT BEFORE STARTING THE ENGINE

Check that:

- The radiator fluid is level;
- The radiator intake grille is clean;
- The engine oil is level;
- The hydraulic oil is level;
- The drive lever is in neutral (fig. 2/N);
- The air filter is clean;
- There is sufficient fuel in the tank.

For detailed fluid levels see 14. Ordinary maintenance and lubrication.

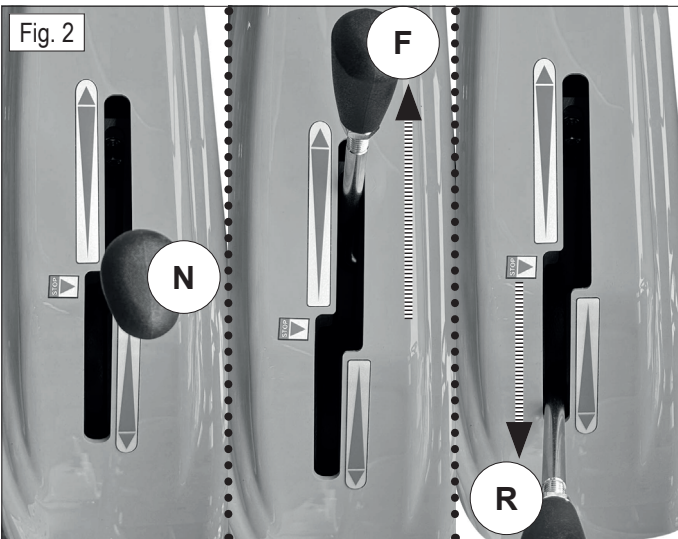

### 10.2 STARTING THE ENGINE

1. Insert the key into the steering column;
2. Turn the key by one position (fig. 3/I) to power up the electrical circuit: the control unit performs a safety and function check, the engine is preheated (glow plug) and the worklight is switched on;
3. Turning the key a further position (fig. 3/II) maintains power to the machine but switches off the worklight;
4. Turning the key to the last position (fig. 3/III) starts the engine;
5. Release the key after starting.

 **IMPORTANT:** always preheat the engine before attempting to start it and wait for the glow warning light to go out (fig. 3/A).

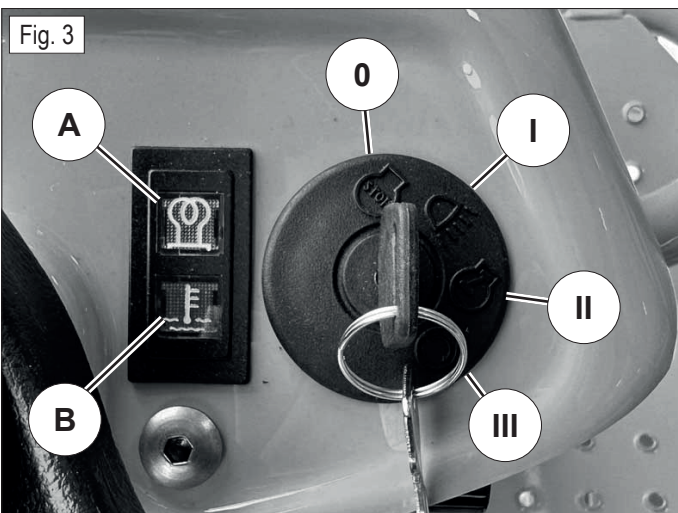

### 10.3 STARTING THE MACHINE

1. Set the cutting height by adjusting the wheels on the flail mower (see 12.2 Cutting height adjustment);
2. Adjust the seat and carry out the necessary checks as described above;
3. Start the engine;
4. Release the parking brake by removing the lever from the housing and moving it to the lowest position (fig. 4/OFF);
5. Move the throttle to halfway (fig. 5/MID);
6. Engage the PTO by pressing the PTO button (fig. 6/A);
7. Always check the operation of the PTO safety devices before starting work, i.e. that:
  - The PTO disengages automatically by getting up from the seat;
  - The rotor stops in less than 5 seconds;
8. Gently push the drive lever forward (fig. 2/F) and start work. Pull the lever backwards (fig. 2/R) for reverse;
9. To stop, simply bring the drive lever to the neutral position (fig. 2/N);
10. By pressing the emergency brake pedal (fig. 7/B), the drive lever will automatically return to the neutral position.

 **IMPORTANT:** do not engage the PTO with the engine at full speed, but bring the engine to half speed and then engage the PTO.

 **IMPORTANT:** during mowing, the flail mower lifting lever must be kept in the FLOAT position (fig. 8/FLOAT).

 **IMPORTANT:** always engage the PTO a few metres before entering the area to be mowed. This cleans the flail mower and does not strain the clutch.

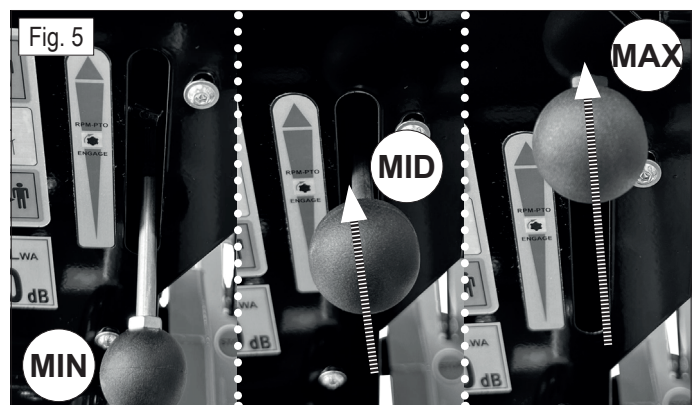
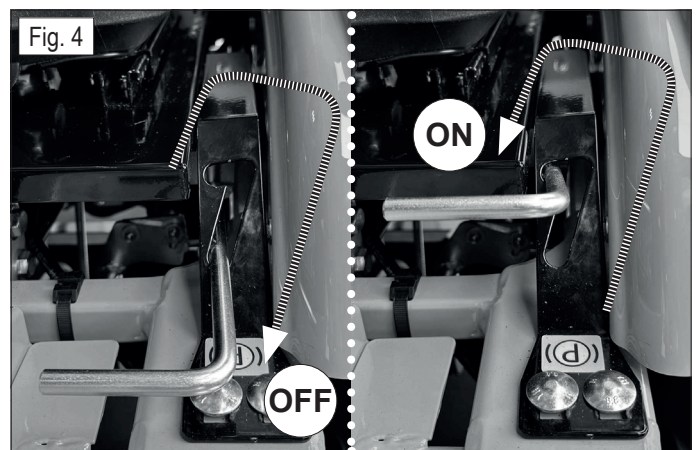

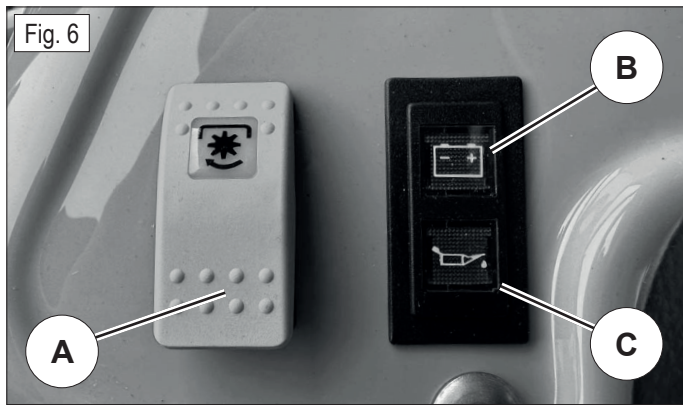

## 10.4 WORK CONCLUSION

Once finished mowing, disengage the PTO and empty the grass catcher. Then:

1. Bring the drive lever to the neutral position (fig. 2/N) to stop;
2. Set the throttle to minimum (fig. 5/MIN);
3. If the flail mower was raised, lower it to the ground;
4. Switch the engine off by turning the key to the stop position (fig. 3/0) and apply the parking brake, pulling the lever upwards and positioning it in the housing (fig. 4/ON);
5. Finish by cleaning the machine.

## 10.5 ORDINARY MACHINE CLEANING

At the end of each job, proper cleaning ensures a long service life for the machine and prevents most common inconveniences.

The best way to clean the machine is with compressed air or a blower/vacuum cleaner.

If necessary, use water for the body parts and the flail mower.

**⚠ CAUTION:** always wear appropriate clothing and goggles before starting any cleaning work.

**⚠ CAUTION:** to reduce the risk of fire, it is very important to keep the engine compartment, muffler, exhaust manifolds, battery, fuel tank area and fuel line clean and free from grass, leaves and dust.

**🔧 IMPORTANT:** do not use a high-pressure washer in the engine compartment and wherever there are electrical components.

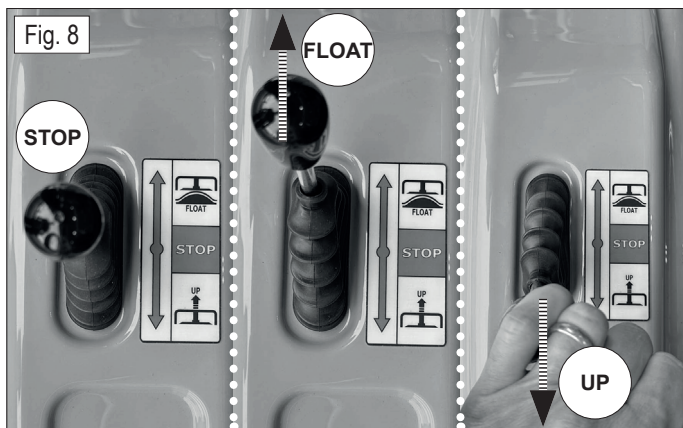
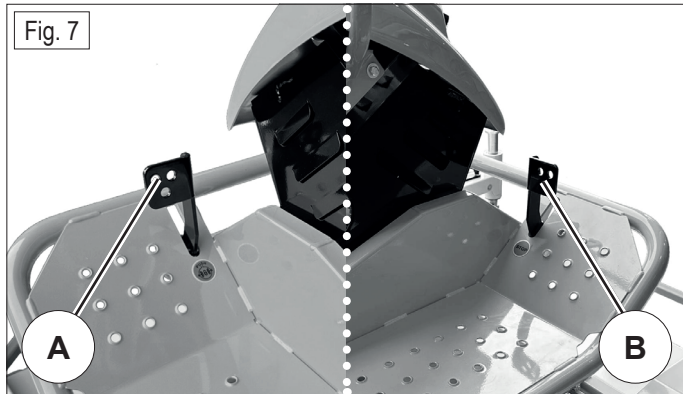

## 10.6 USEFUL RULES FOR CORRECT USE

The machine can work even under severe conditions without clogging problems. A few measures must be taken and all devices must be correctly adjusted.

- Before starting work, check that the flail mower is perfectly clean and free of grass and dirt;
- Check the ground before mowing: ensure there are no stones, roots or foreign bodies;
- When mowing, keep the engine at full revs and adjust the forward speed according to the height of the grass. Be careful and slow down when coming across tall or dense grass;
- Check that the knives are not worn, the cutting edges are sharp and not damaged. Sharpen the knives frequently; the cut will be better and the engine will run at lower consumption.
- Keep the grille in front of the radiator clean;
- If the grass is wet or very high, do not mow with the flail mower in the lowest position, but set it to an intermediate position;
- Check the tension of the belts that drive the PTO (see 13.2 Adjusting the PTO drive belts);

**🔧 IMPORTANT:** the knives must be fitted correctly.

**⚠ CAUTION:** only use the hydraulic lift of the flail mower (fig. 8/UP) for short travel distances, to overcome obstacles, to step on kerbs or curbs.

## 10.7 SLOPING TERRAIN AND DIFFERENTIAL

Steep terrain should be negotiated in uphill/downhill direction as far as possible, taking great care when changing direction and ensuring that the wheels uphill do not encounter any obstacles (stones, branches, roots, etc.) that could cause the machine to lose control. If the drive wheels tend to slip, use the hydraulic control (fig. 8/UP) to lift the flail mower slightly in order to put more weight on the drive wheels and thus have more traction. Consider the various situations and be careful on damp ground and wet grass as the machine may slip. When driving downhill, start at low speed and avoid driving over dry or cut grass as the wheels may lose grip.

It is possible to engage the differential lock by pressing the pedal to the left of the steering column (fig. 7/A) in the condition of wheel slip, or to load the machine on vehicles with ramps. Only engage the differential lock if necessary.

 **CAUTION: avoid slopes that are too steep; comply with the safety limits set out in the manual max 20° (36%).**

## 11. SAFETY DEVICES

### 11.1 ELECTRONIC SAFETY

On the FK 700, an electronic control unit receives signals from the microswitches located on the seat, drive lever and parking brake (see 15.6 Electrical system maintenance). Based on these signals, the control unit generates logic blocks for the safety of the machine and the operator. Specifically, always remember that:

- The engine:
  - Switches off if the operator gets up from the seat with the parking brake off;
  - Will not start if the driver is not seated in the driver's seat, unless the parking brake has been applied first;
  - Will not start if the drive lever is not in neutral position.
- The PTO:
  - Does not activate if the parking brake is applied;
  - Does not activate if the engine is overheated.

### 11.2 PARKING BRAKE

The FK 700 is equipped with a hydraulic drive system, therefore in order to brake it is sufficient to release the drive lever (fig. 2/N). To engage the parking brake, pull the brake lever and position it in the housing (fig. 4/ON). To release the parking brake, simply remove the lever from the housing and move it to a lower position (fig. 4/OFF). If the parking brake is applied and the drive lever is pressed, the buzzer will sound to warn the operator to release the brake.

With the parking brake engaged:

- It is not possible to engage the PTO;
- It is possible to leave the driver's seat with the engine running.

### 11.3 ROLL-BAR

- Roll-over protection is not ensured if the roll-bar is in the lowered position;
- Do not operate the machine on uneven terrain or on slopes with the roll-bar in the lowered position;
- Only lower the roll-bar when absolutely necessary;
- Do not wear the safety belt when the roll bar is lowered;
- Drive slowly and carefully;
- Raise the roll-bar as soon as conditions permit;
- Be careful when working under canopy. Ensure that there are no low branches or other obstacles that could become entangled with the roll-bar.

To lower the roll-bar, proceed as follows:

1. Park the machine on a flat surface;
2. Disengage the PTO, lower the flail mower and engage the parking brake;
3. Switch off the engine;
4. Unfasten the upper screws on the roll-bar (fig. 9/A);
5. Lower the roll-bar behind the seat and tighten the screws in the new position (fig. 10/B).

To raise the roll-bar, proceed as follows:

1. Park the machine on a flat surface;
2. Disengage the PTO, lower the flail mower and engage the parking brake;
3. Switch off the engine;
4. Unfasten the upper screws on the roll-bar (fig. 10/B);
5. Raise the roll-bar and tighten the screws in the new position (fig. 9/A).

**⚠ CAUTION:** in order to avoid serious injuries due to the machine overturning, keep the roll-bar raised and use the safety belt. In addition, make sure that the seat is securely fastened via the securing latch behind the seat (fig. 11/B).

**⚠ CAUTION:** only lower the roll-bar when absolutely necessary, for short periods and raise it immediately as soon as conditions permit.

## 12. ORDINARY ADJUSTMENTS

### 12.1 SEAT ADJUSTMENT

Before starting work, it is recommended to position the seat in the most comfortable position and with the most control over the machine.

- To adjust the seat forwards or backwards use the lever on the right side of the seat (fig. 12/A);
- To adjust the inclination of the backrest use the lever on the left side of the seat (fig. 12/B);
- To adjust the lumbar support use the knob behind the left side of the backrest (fig. 12/C);
- To adjust the seat suspension: pull out the lever in the centre of the seat (fig. 12/D) by turning it counter-clockwise, then press it downwards or pull it upwards repeatedly until the arrow indicator in the lever is in the middle position with the operator seated.
- To tilt the seat, press the latch behind the seat (fig. 11/A); there is also a rod (fig. 11/C) to allow the seat to be kept raised when necessary.

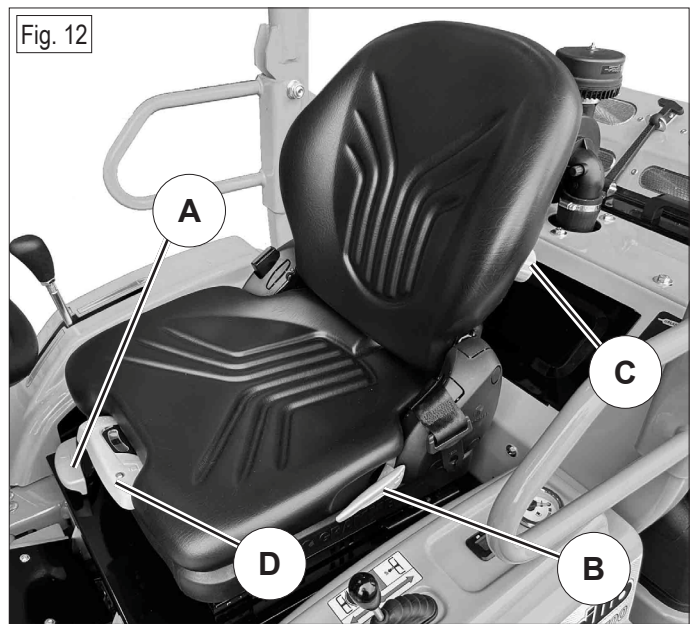
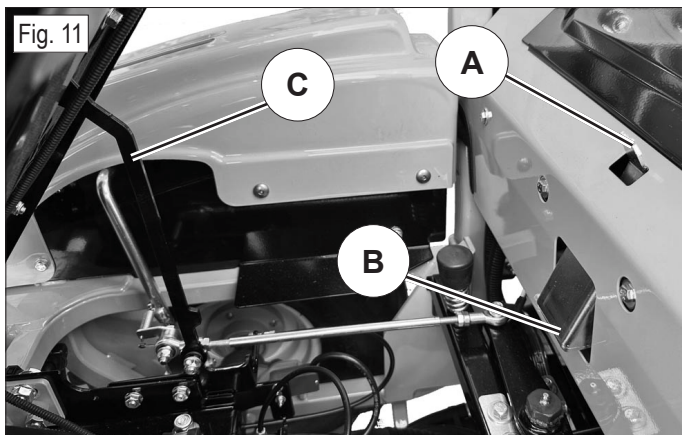
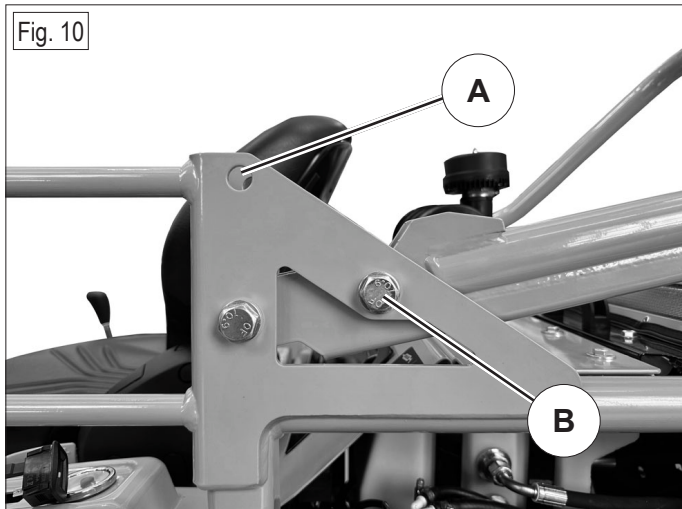
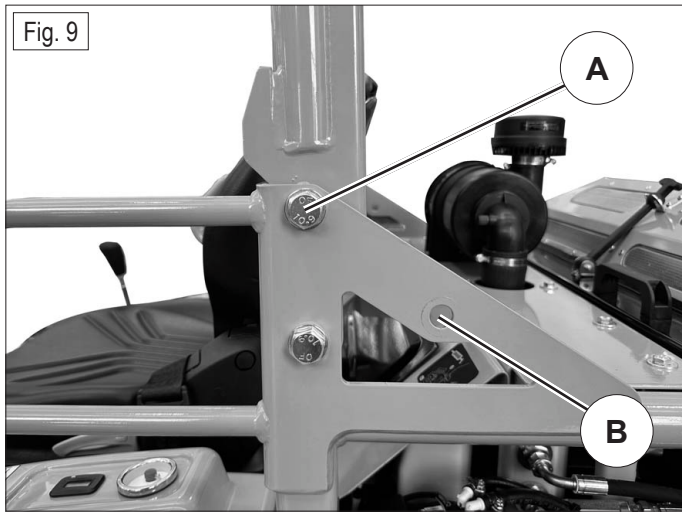

## 12.2 CUTTING HEIGHT ADJUSTMENT

The height of the flail mower is adjustable in 4 fixed positions. To adjust the cutting height:

1. Lift the flail mower with the hydraulic distributor lever (fig. 8/UP);
2. Switch off the engine;
3. Loosen the lever near the flail mower wheel (fig. 13/A);
4. Pull the lever towards the machine (fig. 13/B) and select one of the 4 vertical fork positions (fig. 13/C);
5. Pull the lever back towards the flail mower and tighten it again;
6. Repeat the operation for the other wheel, ensuring that both wheels are adjusted to the same height.

In the event of uneven ground, dips or bumps, it is advisable to operate the flail mower in the highest cutting setting in order to avoid impact on the knives.

 **IMPORTANT:** during cutting, the flail mower lifting lever must be kept in the floating "FLOAT" position, moving it all the way forward (fig. 8/FLOAT).

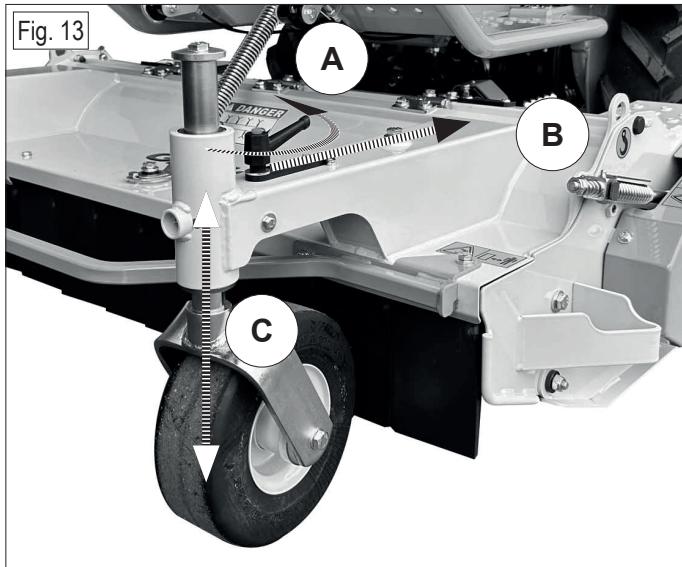

## 12.3 GEAR SELECTION

The FK 700 is equipped with a mechanical two-speed gearbox.

By operating the slow/fast lever in the centre of the steering column, it is possible to select:

- The fast gear 0 - 15 km/h by setting the lever to the left (fig. 14/H);
- The slow gear 0 - 8 km/h by setting the lever to the right (fig. 14/L).

 **IMPORTANT:** all gear changes must strictly be made with the machine stationary, bringing the gear lever into the appropriate slot.

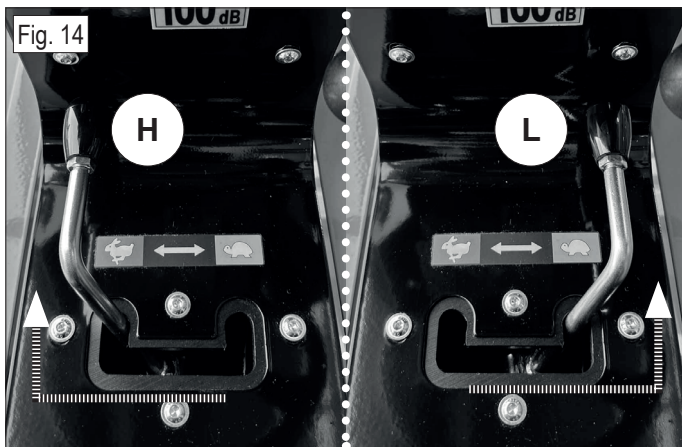

## 13. EXTRAORDINARY ADJUSTMENTS

**⚠ CAUTION:** the adjustment procedures described below require technical skills and expertise.

It is advisable to contact an authorised Grillo centre to undertake these procedures.

### 13.1 ADJUSTING THE PARKING BRAKE

If the parking brake is ineffective, it is possible to adjust it using the adjuster located under the seat: by loosening the bolts (fig. 15/A) it is possible to increase or decrease the opening of the brake caliper by turning the angle of the plate that operates the mechanism (fig. 15/B).

The effectiveness of the brake is the result of the locking of the disc between the two pads at the gearbox output shaft (fig. 15/C). When the brake is not applied, it is important that there is some play ( $0.4 \pm 0.6$  mm) between the pads and the disc and that the linkage is not under tension.

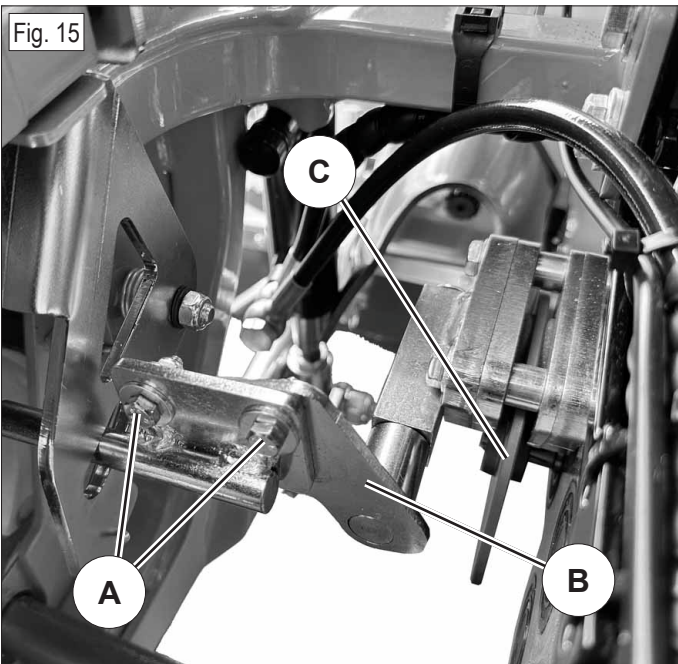

### 13.2 ADJUSTING THE PTO DRIVE BELTS

To adjust the PTO belt tension:

1. Unlock the seat using the lever behind the seat, raise the seat platform and secure it using the rod provided;
2. Loosen the lock nut (fig. 16/A);
3. Tighten/loosen the nut (fig. 16/B) in order to align the tip of the red tension indicator (fig. 16/C) with the end of the spring.

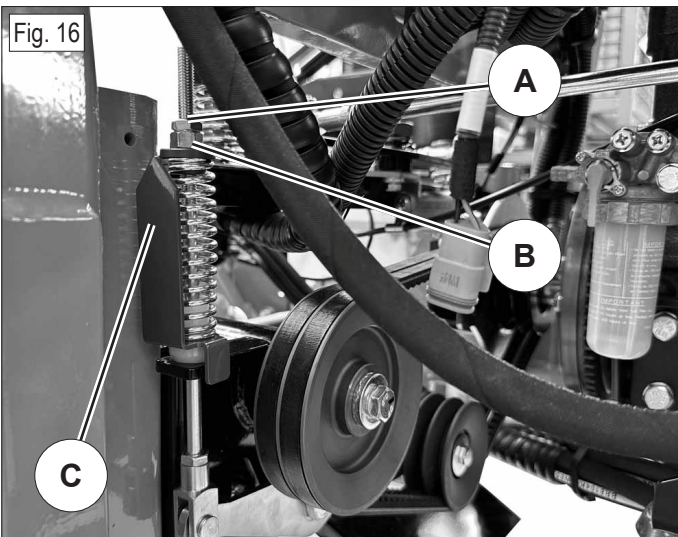

### 13.3 ADJUSTING THE FLAIL MOWER BELTS

To adjust the flail mower belt tension:

1. Loosen the lock nut (fig. 17/A);
2. Screw/unscrew the nut (fig. 17/B) so that the tip of the red tension indicator (fig. 17/C) is aligned with the edge of the spring.

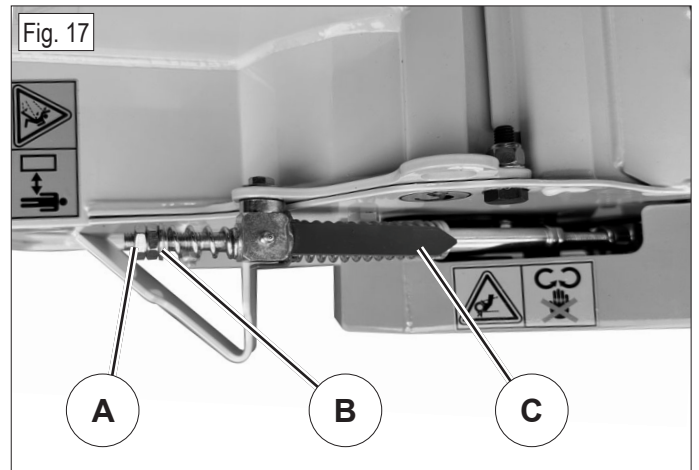

## 14. ORDINARY MAINTENANCE AND LUBRICATION

**CAUTION:** if the machine or part of it has to be lifted, always use suitable tools such as supports and safety locks.

- Always wear appropriate clothing and work gloves before starting any cleaning, maintenance or repair work;
- Do not leave the machine in service without safety devices or lifted, in places accessible to inexperienced persons, especially children;
- Never dispose of waste oil, fuel or any other pollutant in the environment!
- Regular maintenance and correct lubrication help to keep the machine in perfect working order.

### 14.1 LUBRICATION

#### GREASE LUBRICATION POINTS

Consult the location of the lubrication points according to the diagrams on the machine.

For the flail mower, the diagram (fig. 18) shows the components to be lubricated (1 to 6) on which there is a single grease nipple.

The components are:

1. Left swivel wheel;
2. Right swivel wheel;
3. Spring tensioner of the flail mower transmission;
4. Right rotor bearing;
5. Left rotor bearing;
6. Belt tensioner of the flail mower transmission.

For the machine body, the diagram (fig. 19) shows the components to be lubricated (1 to 8), followed by the number of grease nipples present.

The components are:

1. Cardan joint: both crosses;
2. PTO transmission belt tensioner;
3. Drive lever pivot;
4. Belt tensioner of the hydraulic pump transmission;
5. Rear axle: centre pivot and right/left spindles;
6. Right and left front wheel hub bearings;
7. Right and left coupling bracket pivot;
8. Flail mower lifting cylinders, left and right side.

**IMPORTANT:** lubricate with grease every 40 hours all points shown in the diagrams.

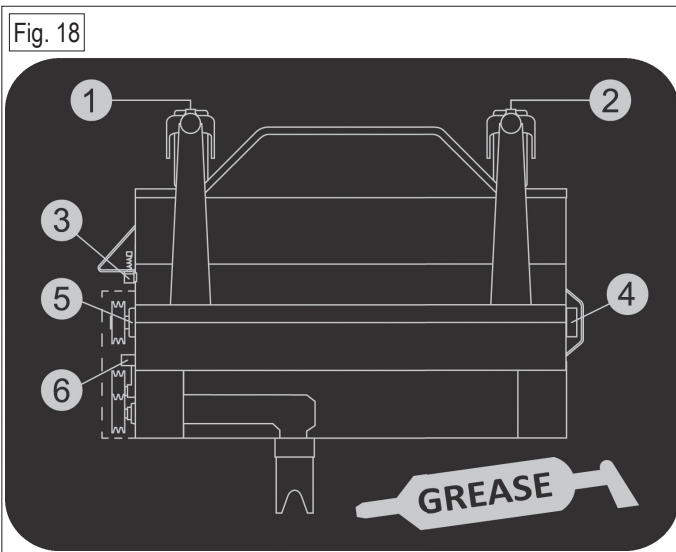
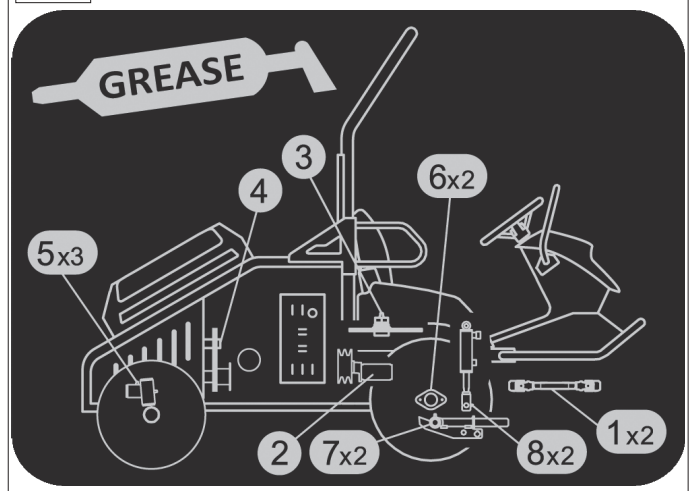

Fig. 19



### 14.2 ENGINE MAINTENANCE

To access the engine: engage the parking brake, switch off the engine and open the rear bonnet (fig. 20/A).

**IMPORTANT:** check the engine periodically, keep the air filter clean and the engine oil level.

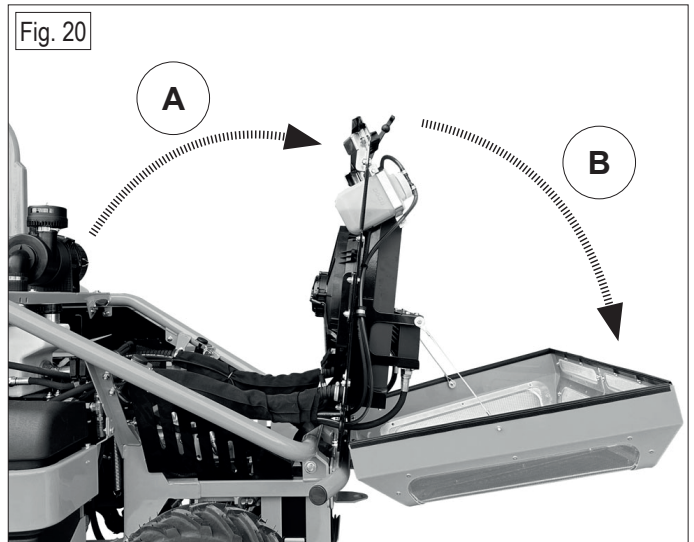

#### AIR FILTER

Check and clean the air filter (fig. 21/A) and the pre-filter (fig. 21/B) every 8 hours. For maintenance intervals and procedures follow the rules contained in this manual (see 17. Maintenance schedule); for further details consult the engine manual. If working in very dusty environments, it is advisable to clean the air filter every 4 hours or as needed. There is also a safety cartridge inside the filter (fig. 22/2) to prevent debris from entering the air intake duct when cleaning the filter. If the filtration element (fig. 22/4) is damaged, replace it. Only replace the safety cartridge if it is damaged or deteriorated.

It is recommended to periodically check the good condition of the air intake duct from the air filter to the engine, and always in the event of a workshop service. Make sure that it is well fixed, that there are no cracks or fissures, that it is not in contact with sharp edges or sharp parts of the machine.

**IMPORTANT:** damage to the air intake duct entails a high risk of engine damage.

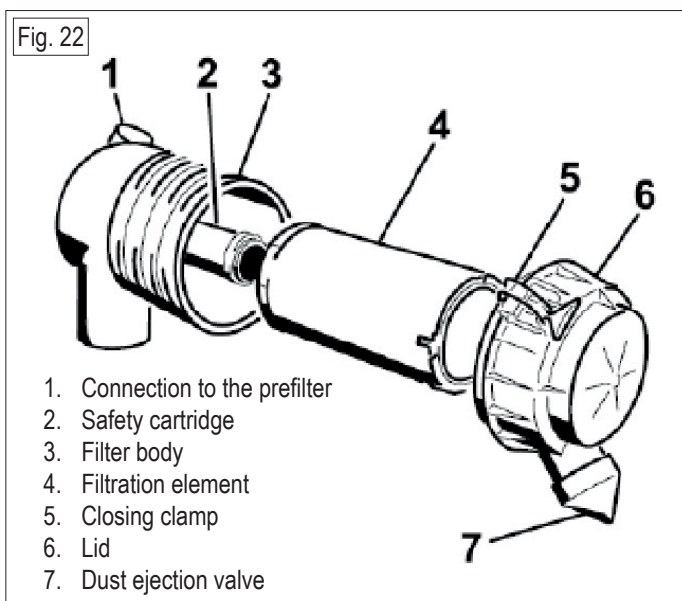
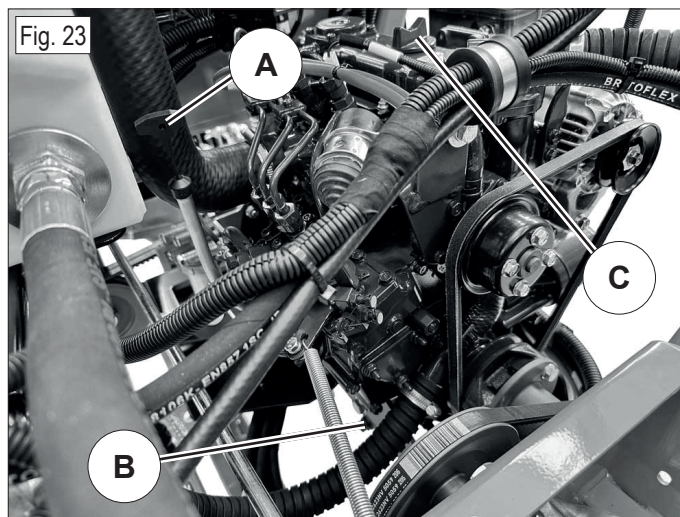
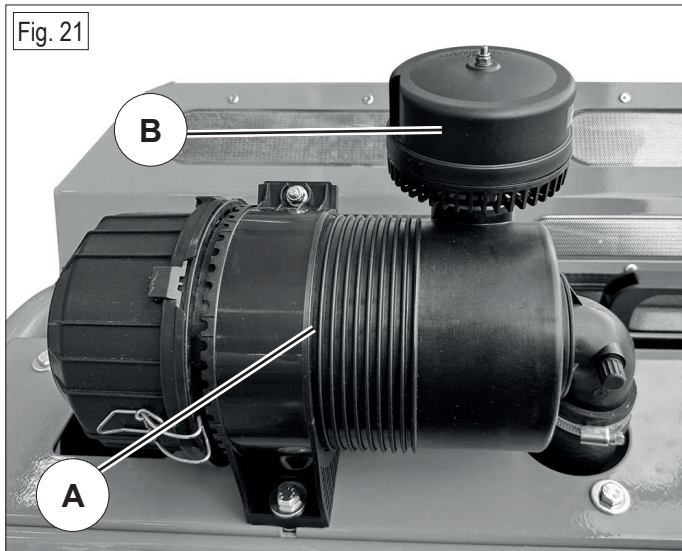

### ENGINE OIL

For lubrication intervals and procedures follow the rules contained in this manual (see 17. Maintenance schedule); for further details consult the engine manual.

For the engine, use SAE 15W40 oil in a quantity of 3.2 litres (including the quantity in the filter).

To check the oil level, use the oil dipstick (fig. 23/A) when the engine is cold. To remove all the oil from the engine unscrew the plug located under the engine sump (fig. 23/B). To add oil or top it up, use the plug located in the upper part of the engine (fig. 23/C).

**IMPORTANT:** it is essential to change the oil and oil filter after the first 50 hours of operation. Then change the oil every 75 hours.

### ENGINE COOLING SYSTEM

In order not to impair the passage of air, check that the protective grille of the radiator is always clean.

The radiator fan is driven by an electric motor; if the radiator grille becomes clogged and the temperature of the coolant rises above 95°C, the fan automatically reverses rotation for a few seconds to clean the grille.

To inspect and clean the fan, open the rear bonnet by pulling the handle (fig. 20/A). To access the radiator, disengage the rubber catch and open the grille (fig. 20/B).

### 14.3 BATTERY MAINTENANCE

The battery does not require any special maintenance.

It is sufficient to check that the voltage is not lower than 12.5 Volts and recharge it if necessary. To access the battery open the rear bonnet (fig. 20/A).

To recharge the battery it is necessary to disconnect the cables and remove the battery from the machine (see 15.7 Battery replacement).

It is recommended to periodically check the good condition of the positive (red) electrical cables connecting the battery with the fuses, starter motor and alternator, and always in the event of a workshop service. Check that they are secure, not marked by wear, and not in contact with sharp edges or sharp parts of the machine.

**CAUTION:** damage to electrical cables can cause short circuits and fire hazards.

**CAUTION:** charging has to be carried out in a dry and ventilated area, free of sparks and heat sources.

**CAUTION:** do not reverse the polarity of the battery, and be careful not to cause a short circuit.

**CAUTION:** the gases released by the battery are explosive, keep it away from flames or sparks.

**IMPORTANT:** do not attempt to start the machine if the battery is not correctly secured and connected: the alternator and the control unit could be damaged.

## 14.4 FLAIL MOWER MAINTENANCE

To inspect the cutting rotor, switch off the engine, engage the parking brake and proceed as follows:

1. Slightly lift the flail mower with the hydraulic distributor lever (fig. 8/ UP) in order to relieve its weight from the ground;
2. Manually lift the footplate and secure it with the latch (fig. 24/A);
3. Loosen the 5 fixing screws (fig. 24/B);
4. Lower the flail mower with the hydraulic distributor lever (fig. 8/ FLOAT);
5. Lift the wheel assembly (fig. 25/A) in order to release the spring that anchors it to the machine (fig. 24/C);
6. Secure the wheel assembly in the open position using the provided rod (fig. 25/B).

In the raised position, the transmission belts are automatically slackened. To return to the working position, carry out the described procedure in reverse, remembering that the footplate latch will automatically disengage when the footplate is raised further upwards.

**⚠ CAUTION:** carry out the operation only when the engine is switched off and the brake is applied.

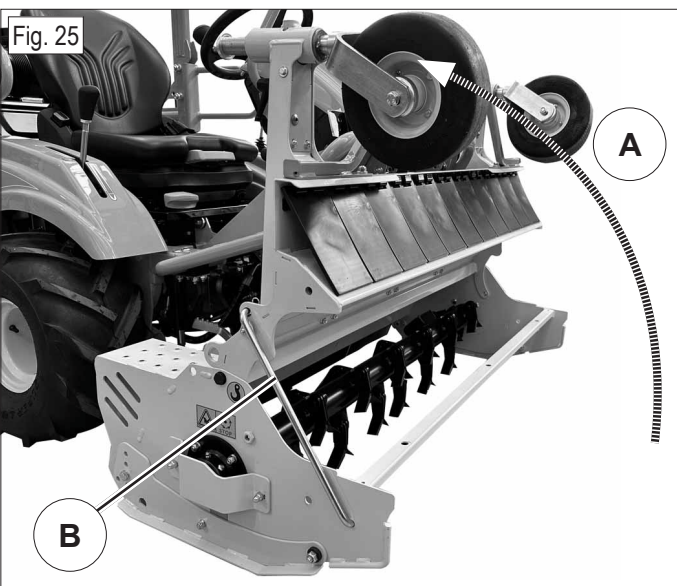
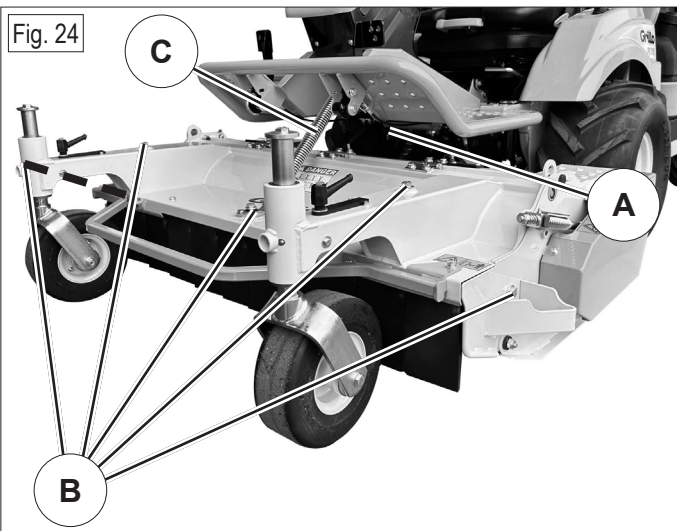

## 15. EXTRAORDINARY MAINTENANCE

**⚠ CAUTION:** the operations contained in this chapter require technical skills and special equipment. It is advisable to contact an authorised Grillo centre.

### 15.1 FUEL SYSTEM MAINTENANCE

#### FUEL FILTER AND FUEL CIRCUIT

The fuel filter cartridge is located on the left-hand side of the machine, near the engine (fig. 26). For maintenance intervals and methods follow the rules contained in this manual (see 17. Maintenance schedule); for further details consult the engine manual.

Running out of fuel in the tank can cause the engine to stop and have difficulty restarting. In this case it is necessary to carry out the procedure of bleeding the air from the fuel circuit using the hand pump located behind the diesel tank (fig. 27).

#### BLEEDING AIR FROM THE FUEL CIRCUIT

Proceed as follows:

1. Fill the tank to at least half full;
2. Keep the filter tap in the open position (fig. 26/A);
3. Loosen the bleed screw (fig. 26/B) on the engine.
4. Press the hand pump several times until fuel starts to flow out from the screw, then tighten it;
5. Try to start the machine; more than one attempt may be necessary. Always wait for the preheat warning light to go out before starting the engine.

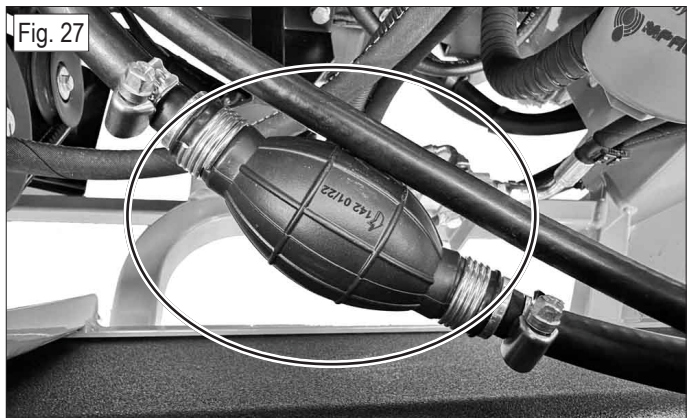
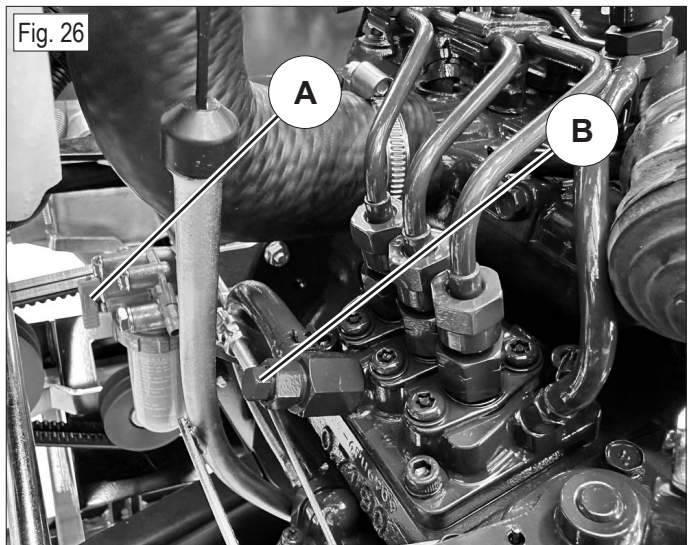

## 15.2 COOLING SYSTEM MAINTENANCE

### CHANGING THE COOLANT

1. With the engine switched off and cold, open the rear bonnet and open the radiator grille (fig. 20);
2. Unscrew the radiator cap (fig. 28/A) and the screws underneath (fig. 28/B) in order to remove the old fluid completely;
3. Retighten the lower screws and pour the new fluid into the radiator until it is completely filled;
4. Close the radiator cap, top up the reservoir to about a quarter of its capacity (fig. 28/C) and then close the bonnet.

**⚠ CAUTION: danger of hot liquid escaping under pressure, always wear suitable work gloves for this operation. Do not undertake the following operation when the engine is hot.**

### BLEEDING AIR FROM THE COOLING SYSTEM

In order to facilitate correct engine cooling, it is important that there is no air in the cooling system. Therefore, make sure that the clamps on the cooling water hoses are tight and that no air enters the circuit.

After changing the coolant, check the level after letting the engine run for 15 minutes at half speed, and then again after one hour of using the machine. If necessary, top up the reservoir after allowing the engine to cool.

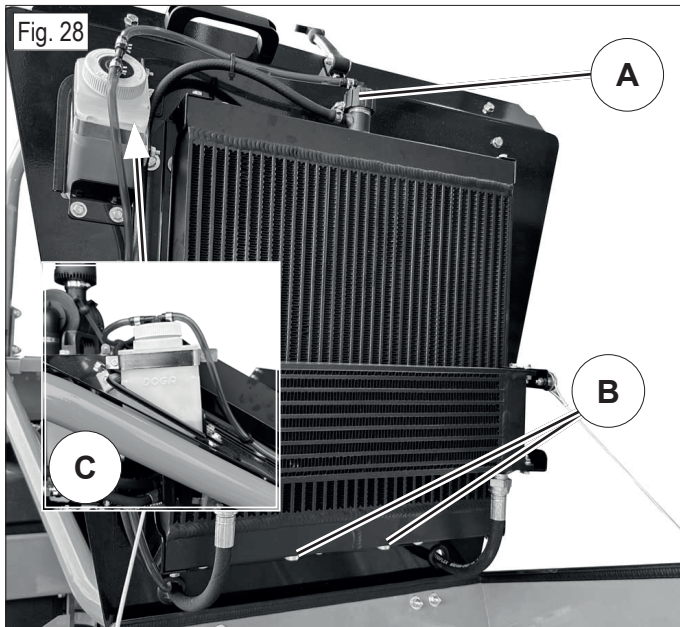

## 15.3 HYDRAULIC SYSTEM MAINTENANCE

The hydraulic lever distributor (fig. 8) operates at a maximum operating pressure of approximately 140 bar. It makes the flail mower floating or can lift it.

Check the level in the hydraulic oil tank (fig. 29/A) periodically, when the oil is cold. To check the level or to top up the oil, unscrew the oil level cap. Check the level by using the dipstick (fig. 29/B) of the oil tank cap: the level must be between the two notches at the end of the dipstick. Check the level by screwing the cap on and off completely each time. To remove the oil, loosen the hydraulic hose on the gear pump (fig. 29/C).

Change the hydraulic oil and oil filter (fig. 29/D) the first time after 100 hours, then every 400 hours. It is not necessary to bleed the hydraulic system. Pay attention to the degree of filtration of the filter (10 µm).

The oil must be changed before 100 hours if:

- The oil is dark in colour;
- The oil is off-white in colour (oil is contaminated with water);
- There are black residues (partial deterioration of the oil).

Use hydraulic oil 5W50 in a quantity of 6.5 litres including filling the circuit and the filter.

**⚠ IMPORTANT: pay particular attention to any contamination that could enter the circuit and cause serious damage to the machine.**

HYDRAULIC PRESSURES	
Closed loop transmission: variable displacement pump and hydraulic motor	200 bar
Hydroguide	140 bar
Lever distributor	140 bar
Charge pressure of the hydraulic pump	5 bar

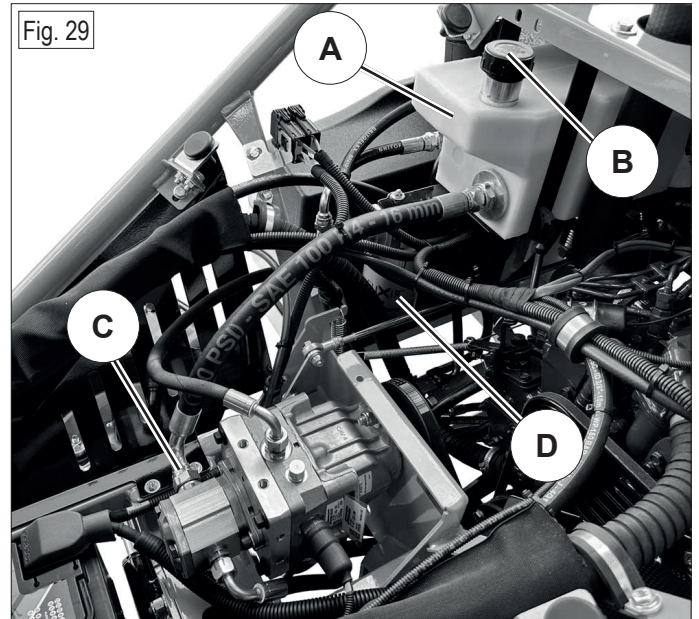

## 15.4 FLAIL MOWER MAINTENANCE AND COMPLETE DISASSEMBLY

Proceed as follows to remove the flail mower:

1. Raise the flail mower with the hydraulic distributor lever (fig. 8/UP) and then release the anchor spring on the machine (fig. 24/C);
2. Lower the flail mower by bringing the distributor lever to the float position (fig. 8/FLOAT);
3. Unscrew the cardan shaft guard screw (fig. 30/A) and release the cardan shaft by pressing the unlocking button (fig. 30/B);
4. Remove the cotter pins from the pins of the lift arms and slide the pins out (fig. 30/C);
5. Press the uncoupling pedal (fig. 30/D) on the two quick couplings of the flail mower;
6. Fully press the ejection pedal on the two lifting arms (fig. 30/E) until both arms have completely come out of the two quick couplings of the attachment, then move the hydraulic distributor lever to the stop position (fig. 8/STOP);
7. Move the flail mower away from the machine by pulling it outwards, or by reversing the machine.

To reinstall the flail mower:

1. Push the flail mower towards the machine, or approach the machine until the lifting arms are at the end of their stroke on the flail mower quick coupling;
2. Raise the flail mower with the hydraulic distributor lever to engage the quick couplings;
3. Insert the pins of the quick couplings and secure them with the cotter pin;
4. Connect the cardan joint to the flail mower and reposition the guard.

**⚠ CAUTION:** carry out the operation with the engine switched off and the brake applied.

**⚠ CAUTION:** before starting the machine, it is nevertheless good practice to ensure that the cardan shaft is properly connected on both the flail mower and the machine and the stop button is protruding (fig. 31).

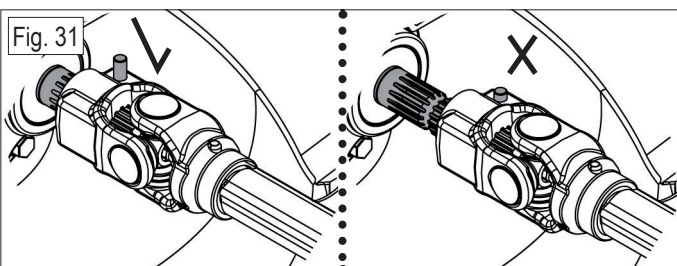
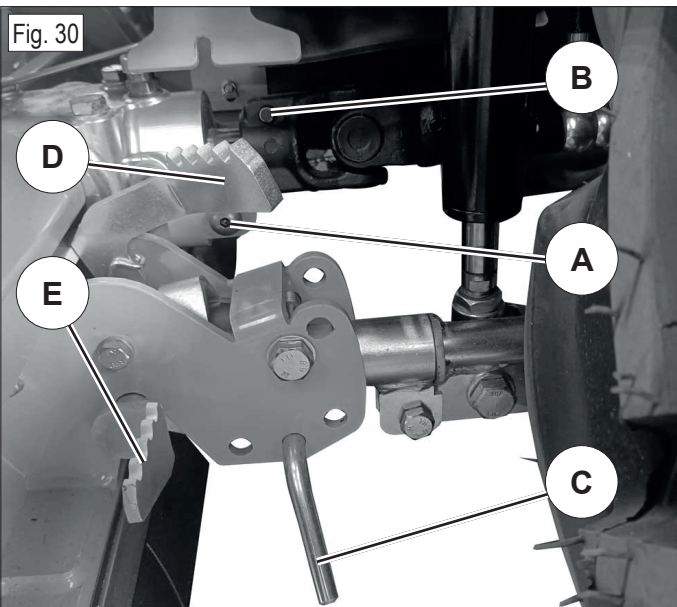

## SHARPENING THE KNIVES

An unsharpened or damaged knife can impair the correct operation of the flail mower as, in addition to cutting inefficiency, it can lead to unbalance of the system causing possible damage to the transmission and the structure itself.

If garden knives are used, pay attention to the direction of rotation and correct assembly of the knives (fig. 32).

**⚠ CAUTION:** never attempt to repair damaged knives. Damaged knives must be replaced.

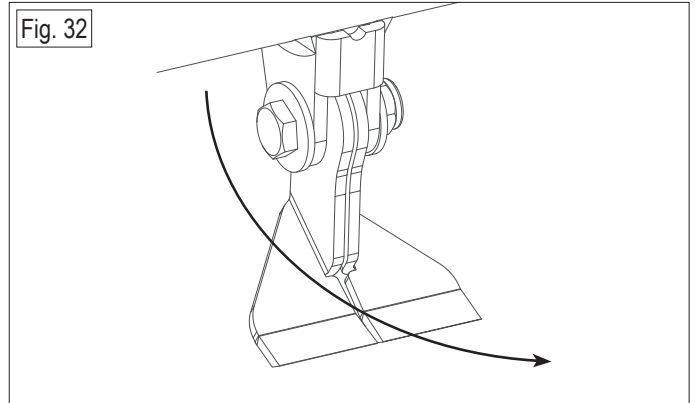

## FLAIL MOWER GEARBOX

Use LSX 75W90 synthetic oil in a quantity of 0.14 litres.

Change the oil every 300 hours.

To change the gearbox oil, it is necessary to remove the gearbox from the flail mower by removing the drive belts, pulley and swivel bearing, then unscrew the inspection plug on the rear of the gearbox (fig. 33/A) and drain the oil completely.

If any oil leaks are noticed, we recommend contacting the authorised Grillo service centre.

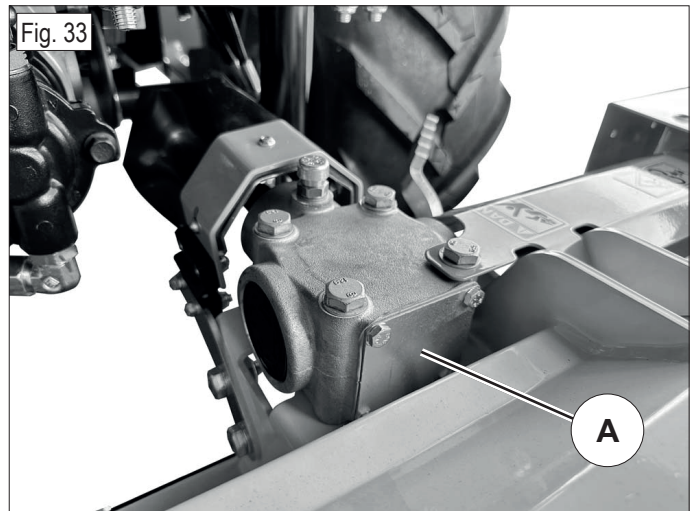

## 15.5 DRIVING BELT MAINTENANCE

**⚠ IMPORTANT:** only use genuine belts.

### REPLACING THE FLAIL MOWER BELTS

For their replacement proceed as follows:

1. Lift the flail mower wheel assembly to release the tension on the drive belts (see 14.4 Flail mower maintenance);
2. Remove the transmission cover by removing the fixing screws (fig. 34/A);
3. The belts can now be replaced.

Once replacement is complete, proceed as follows:

1. Lower the flail mower wheel assembly;
2. Refit the transmission cover;

3. Tension the belts by bringing the spring to the correct compression so that the tip of the red tension indicator is aligned with the end of the spring (see 13.3 Adjusting the flail mower belts).

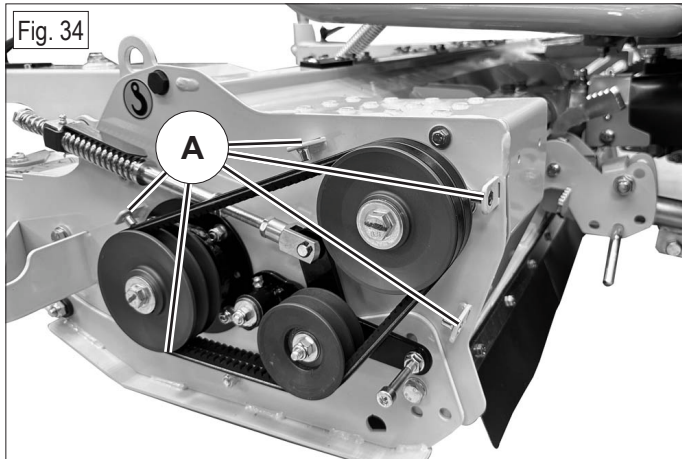

### REPLACING THE PTO BELTS

For their replacement proceed as follows:

1. Tip the seat and secure it in place with the support rod;
2. Unscrew the two bolts securing the fuel tank (fig. 35/A) and pivot the fuel tank (fig. 35/B) to gain access to the clutch;
3. Disconnect the electrical cable of the electromagnetic clutch (fig. 36/A);
4. Remove the bracket (fig. 36/B) fixed to the frame with two bolts (fig. 36/C);
5. Loosen the spring that adjusts the belt tensioner by unscrewing the nuts (fig. 36/D);
6. The belts can now be replaced.

Once replacement is complete, proceed as follows:

1. Reposition the bracket in its original position and connect the electric cable to the clutch;
2. Tension the belts, bringing the spring of the belt tensioner to the correct compression, so that the tip of the red tension indicator is aligned with the end of the spring (see 13.2 Adjusting the PTO drive belts).

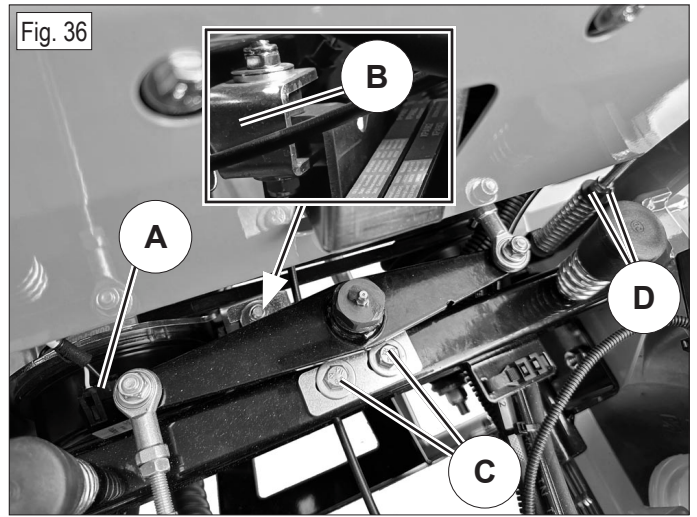
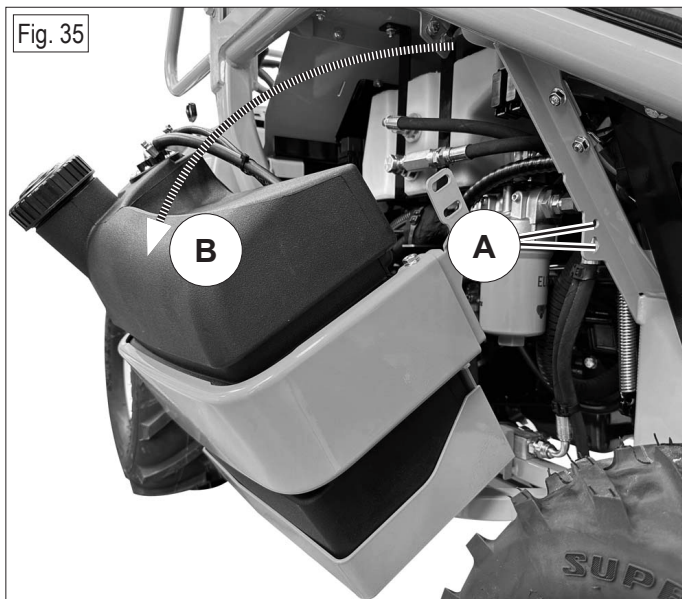

### REPLACING THE HYDRAULIC PUMP BELT

To replace the pump belt, proceed as follows:

3. Unhook the spring of the idler pulley (fig. 37/A);
4. Manually lift the idler pulley (fig. 37/B);
5. The belt can now be replaced.
6. Once the replacement is complete, re-attach the idler spring. The hydraulic pump belt does not need to be adjusted as it is self-adjusting.

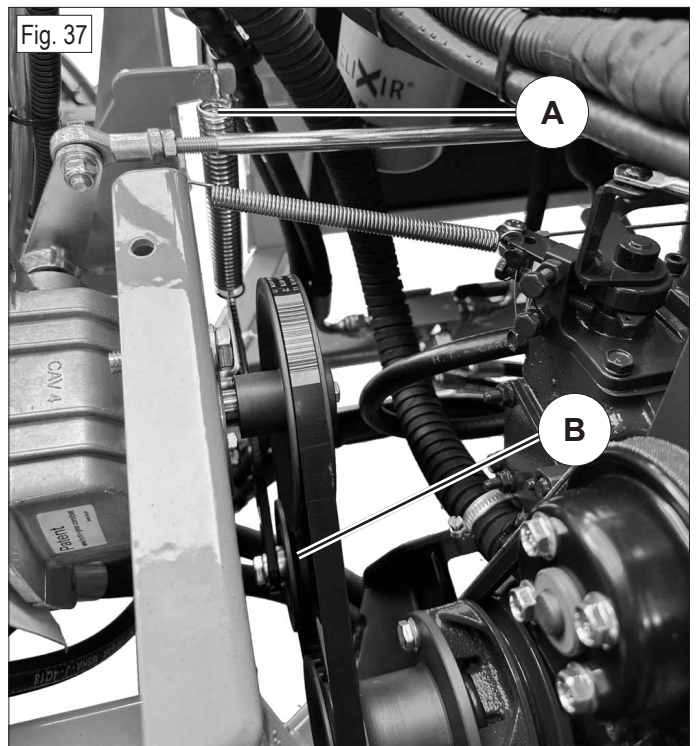

## 15.6 ELECTRICAL SYSTEM MAINTENANCE

### FUSES

The electrical system is protected by fuses that, if interrupted, will cause the complete ineffectiveness of the whole electrical system. There are two main 40 A fuses: one protects the entire electrical system (fig. 38/A) and the other protects the radiator fan (fig. 38/B). Behind the seat there are other fuses to protect the components of the electrical system (fig. 39/A). If electrical problems persist after the fuses have been replaced, contact the authorised service centre. Never attempt to undertake major repairs without having the necessary means and expertise.

 **IMPORTANT:** do not replace fuses with fuses of a different rating than those indicated in the manual and on the relevant decal behind the fuse cover.

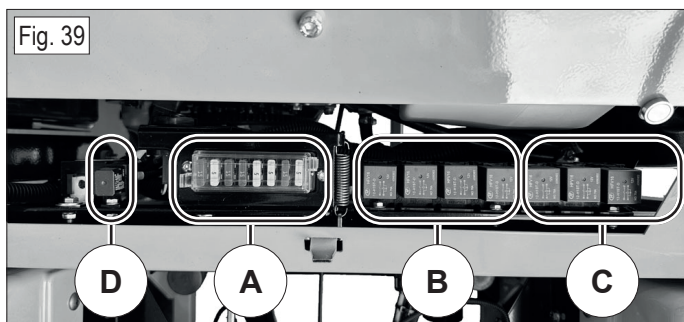
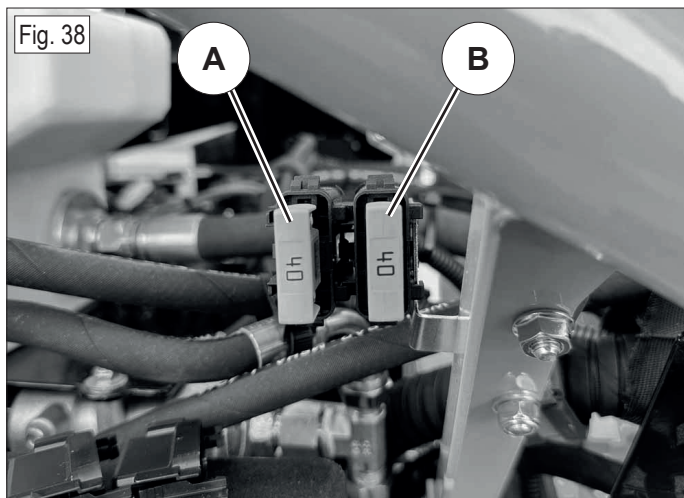

### ENGINE TEMPERATURE SENSOR

A sensor that detects the temperature of the coolant is located on the engine head:

- When the temperature of the coolant exceeds 95°C, the sensor sends a signal to the control unit located underneath the right fairing that triggers the automatic cleaning cycle of the radiator, reversing the direction of rotation of the fan for a few seconds, cleaning the grille;
- If the coolant temperature exceeds 105°C, an acoustic alarm is triggered and the warning light on the instrument panel is lit (fig. 3/B). The PTO is automatically disengaged;
- If the coolant temperature exceeds 110°C, the engine is shut down.

If the sensor is faulty or absent, it will not be possible to start the engine and the control unit will signal the sensor failure by activating a continuous acoustic alarm.

### RELAYS

Positioned behind the seat are:

- 4 radiator fan control relays (fig. 39/B);
- 4 engine power supply relays: ignition key, glow plugs, starter motor, solenoid (fig. 39/C);
- 1 power relay for the electromagnetic clutch (fig. 39/D).

### NEUTRAL POSITION MICROSWITCH

The drive lever activates a microswitch (fig. 40/A) that signals the neutral position of the machine.

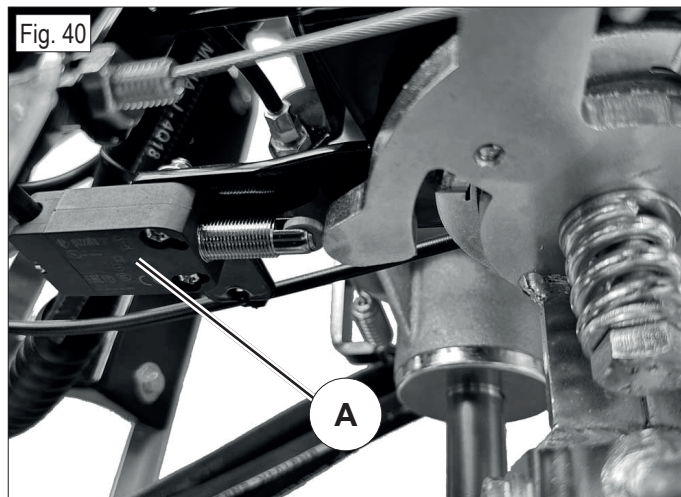

### PARKING BRAKE MICROSWITCH

The parking brake lever activates a microswitch (fig. 41/A) that signals that the brake is applied and allows the engine to keep running even if the operator leaves the driver's seat.

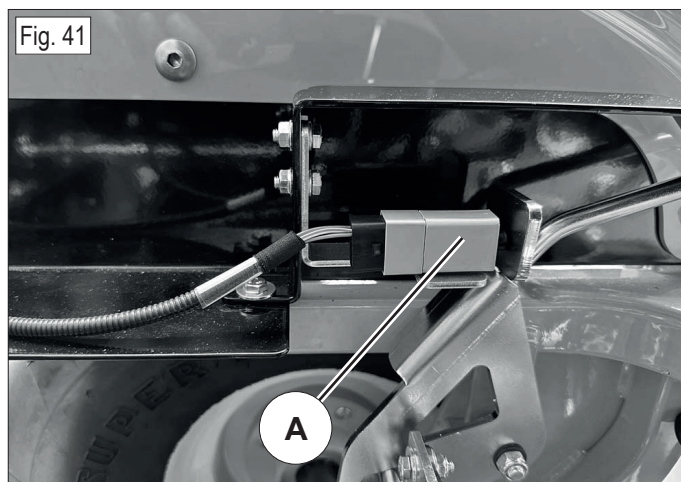

### HOUR METER

The hour meter is located on the left fairing and indicates the hours the machine has worked.

- Pressing the button below the screen once will display how many hours remain until the next engine oil change (OIL flashing, followed by the number of hours remaining);
- Pressing the button again will display how many hours remain until the next lubrication at the greasing points (LUBE flashing, followed by the number of hours remaining);
- Pressing the button again will return to the working hours screen.

When there are 10 hours left for oil / 5 hours left for grease, the OIL / LUBE signs will start to flash. They will continue counting the missing hours, until they show the OIL NOW / LUBE NOW writing: at this point it is advisable to carry out maintenance in a short time.

Once maintenance has been carried out, to reset the hour count go to the screen to be reset (e.g. OIL) and hold down the button until a series of

zeros (000000) appears.  
The count is automatically reset.

### OPERATOR PRESENCE MICROSWITCH

The operator presence microswitch is located under the seat and detects the presence of the operator when seated in the driver's seat.

## 15.7 BATTERY REPLACEMENT

To access the battery and replace it if the machine breaks down, the ignition key must be in the off position and the parking brake must be applied. Unscrew the bumper with the tow hitch and the cover above the battery (fig. 42/A), then disconnect the cables (**first the negative BLACK one and then the positive RED one**) and after loosening the screw of the fixing plate (fig. 42/B) remove the flat battery.

Insert the new battery and connect the cables (**first the positive RED cable and then the negative BLACK cable**), tighten the screw of the fixing plate and refit the cover and the bumper.

If the replacement battery has been supplied as a "dry" replacement with separate acid, choose a suitable dry, well-ventilated location free from sparks and heat sources for installation and then proceed as follows:

1. Insert the acid and wait 2 hours;
2. Charge the battery with a battery charger set to 12 Volts on slow charge for 2 hours.

Check the fluid level periodically and keep the terminals lubricated with petroleum jelly.

**⚠ CAUTION:** failure to do so may lead to battery deterioration and acid leakage during work.

**⚠ CAUTION:** the gases released by the battery are explosive, keep it away from flames or sparks.

**⚠ CAUTION:**

- Do not reverse the polarity of the battery;
- Do not operate the machine without the battery;
- Take care not to cause a short circuit.

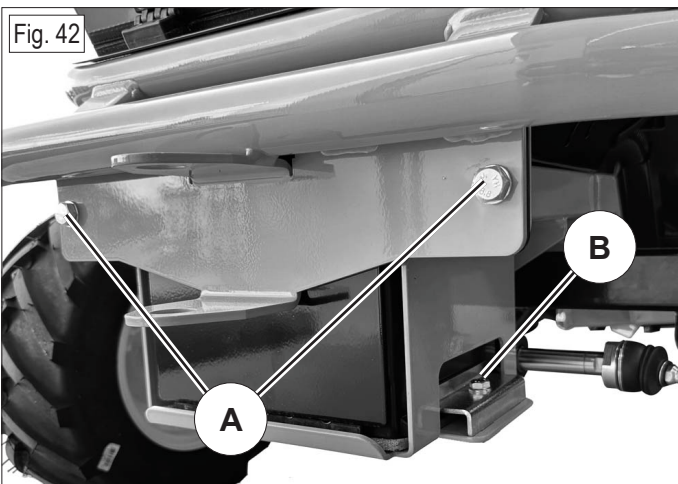

## 15.8 WHEEL MAINTENANCE

Use only Tubeless 4-ply (4PR) tyres in sizes 20x10.50-8 for the front and 16x6.50-8 for the rear.

Routinely check the tyre pressure, which should be 1.5 bar (21 psi) for all four wheels.

Always ensure that the valve protection cap is in place. The purpose of the cap is to prevent foreign bodies from entering the valve, damaging it and causing pressure loss; always tighten the cap by hand.

In the event of impacts against curbs or other obstacles, it is important to visually check the condition of the tyres: a bulge in the sidewall, for example, may indicate an internal structural damage that would make the tyre unusable.

It is recommended to periodically check the correct tightening of the drive wheel hubs on the shafts, and always in the event of a workshop service: In particular, check that:

- The tightening marks are aligned (fig. 43);
- The tightening torque is 300 Nm. Only tighten with a torque wrench to ensure the correct torque value.

**⚠ CAUTION:** tightening the hubs to a torque value other than the prescribed one can cause serious damage to the wheel axle, can endanger the operator and can lead to expensive repairs.



## 16. TROUBLESHOOTING GUIDE

FK 700 - TROUBLESHOOTING GUIDE		
PROBLEM	CAUSE	SOLUTION
The dashboard remains off, with the key in any position besides the STOP position.	The battery does not supply any current	<ul style="list-style-type: none"> <li>- Check the battery cut-off switch</li> <li>- Check the connection cables</li> <li>- Check the electrolyte level in the battery</li> <li>- Recharge the battery</li> <li>- Check the integrity of the fuses</li> <li>- Check the ground connections on the engine</li> </ul>
The dashboard is switched on, the key is in a position other than STOP, but the starter motor does not rotate	The battery does not supply sufficient current	<ul style="list-style-type: none"> <li>- Recharge the battery</li> <li>- The battery has no ground connection</li> <li>- Check the integrity of the fuses</li> </ul>
	No start consent	<ul style="list-style-type: none"> <li>- The forward/reverse lever is not in neutral</li> <li>- Sit in the driver's seat to activate the microswitch, or apply the parking brake</li> <li>- High engine temperature</li> <li>- Check for a defective microswitch</li> <li>- Faulty ignition key block</li> </ul>
Difficult starting or irregular engine operation	Combustion issues	<ul style="list-style-type: none"> <li>- Clean or replace the air filter</li> <li>- Check that there is no air intake in the fuel circuit</li> <li>- Bleed the air from the fuel circuit</li> </ul>
	Deposits or contamination in the fuel	<ul style="list-style-type: none"> <li>- Check and, if necessary, replace the fuel filter</li> <li>- Consult the engine manual</li> </ul>
	Injection issues	<ul style="list-style-type: none"> <li>- Consult the engine manual</li> </ul>
The starter motor rotates but the engine does not start	No fuel flow	<ul style="list-style-type: none"> <li>- Check the fuel level in the tank</li> <li>- Check (and replace if necessary) the fuel filter</li> <li>- Bleed the air from the fuel system</li> </ul>
	Poor glow plug preheating when the engine is cold	<ul style="list-style-type: none"> <li>- Wait until the preheating light has gone out</li> <li>- Check that the glow plugs are working properly</li> </ul>
	Stop solenoid	<ul style="list-style-type: none"> <li>- Manually check the sliding of the stop lever</li> </ul>
	Timer relay	<ul style="list-style-type: none"> <li>- Replace the timer</li> <li>- Check the electrical connection</li> </ul>
Drop in motor efficiency during cutting	High forward speed in relation to cutting height	<ul style="list-style-type: none"> <li>- Reduce the forward speed</li> <li>- Place the flail mower in a higher cutting position</li> </ul>
	Flail mower transmission	<ul style="list-style-type: none"> <li>- Check the integrity of the bearings and belt tensioners of the flail mower</li> <li>- Lubricate the flail mower using the grease nipples indicated</li> </ul>
The motor switches off when the PTO is activated	<ul style="list-style-type: none"> <li>- Knives</li> <li>- Belt tensioners</li> <li>- Flail mower gearbox</li> </ul>	<ul style="list-style-type: none"> <li>- Check the integrity of the bearings and belt tensioners of the flail mower</li> <li>- Check the flail mower gearbox</li> <li>- Check the rotor and transmission for obstructions</li> </ul>
Irregular cutting	Knives inefficiency	<ul style="list-style-type: none"> <li>- Check the correct fitting of the knives</li> <li>- Sharpen or replace the knives</li> <li>- Adjust the tension of the PTO belts</li> <li>- Adjust the tension of the flail mower transmission belts</li> </ul>
	High forward speed in relation to cutting height or grass conditions	<ul style="list-style-type: none"> <li>- Reduce the forward speed</li> <li>- Place the flail mower in a higher cutting position</li> </ul>
Vibrations during operation	Unbalanced knives	<ul style="list-style-type: none"> <li>- Balance or replace knives if damaged</li> <li>- Check the integrity of the bearings and belt tensioners</li> </ul>
	Accidental knocks on kerbs, walls, etc.	<ul style="list-style-type: none"> <li>- Check knives, frame and engine fixing bolts and tighten any loose bolts</li> </ul>
Engine oil warning light switches on	Insufficient engine oil pressure	<ul style="list-style-type: none"> <li>- Check and restore engine oil level</li> <li>- Change the engine oil filter</li> </ul>

**FK 700 - TROUBLESHOOTING GUIDE**

PROBLEM	CAUSE	SOLUTION
The PTO does not engage	<ul style="list-style-type: none"> <li>- Parking brake applied</li> <li>- Faulty switch</li> <li>- Defective clutch</li> <li>- Defective parking brake microswitch</li> <li>- High engine temperature</li> </ul>	<ul style="list-style-type: none"> <li>- Check the PTO button</li> <li>- Check the function and integrity of the clutch</li> <li>- Check the fuses</li> <li>- Check the operation and adjustment of the parking brake microswitch</li> <li>- Check the parking brake microswitch connectors</li> <li>- Check engine temperature warning light</li> </ul>

 **CAUTION!** If problems persist after carrying out the actions described in this manual, contact the authorised service centre. Never attempt to carry out major repairs without having the necessary means and technical expertise.

**IF YOU HIT A STONE OR ANOTHER FOREIGN BODY:**

1. Disengage the PTO;
2. Lift the flail mower;
3. Switch off the engine and apply the parking brake;
4. Check the bolts securing the knives and the integrity of the flail mower;
5. Check that the foreign body is not jammed in the rotor.

## 17. MAINTENANCE SCHEDULE

FK 700 - MAINTENANCE SCHEDULE									
MAINTENANCE ITEM		EVERY 8 HOURS	FIRST 20 HOURS	EVERY 40 HOURS	EVERY 50 HOURS	EVERY 75 HOURS	EVERY 100 HOURS	EVERY 150 HOURS	BEYOND
Engine oil	Check the level	●							
	Replace				● (FIRST CHANGE)	●			
Engine oil filter	Replace				● (FIRST CHANGE)			●	
Air filter	Check	●							
	Replace						*		
Hydraulic system oil and filter	Check		●		●				
	Replace						● (FIRST CHANGE)		● (EVERY 400 HOURS)
Front axle oil	Replace								● (FIRST CHANGE AT 500 HOURS THEN EVERY 1000 HOURS)
Coolant	Replace	● EVERY 1000 HOURS OR ONCE A YEAR							
Check the cleanliness of the radiator intake grille		●							
Check the sharpness and fixing of the knives			●			●			
Grease lubrication				●					
Check the good condition of the air intake duct				●					
Check the good condition of the positive electrical cables				●					
Check the tightness of the drive wheel hubs and tyre pressure (1.5 bar - 21 psi)				●					
Diesel filter	Check						●		
	Replace								● (EVERY 400 HOURS)
Flail mower gearbox oil	Replace								● (EVERY 300 HOURS)

● recommended task

\* task to be carried out if necessary

## 18. LUBRICATION CHART

FK 700 - LUBRICATION CHART			
Engine oil	15W40	3.2 L	Replace after the first 50 hours of work and every 75 hours thereafter
Coolant	50% water 50% antifreeze	5.2 L	Empty and wash the reservoir then add fluid every 1000 hours or once a year
Front axle oil	ISO VG220	1.6 L	Replace after the first 500 working hours and every 1000 hours thereafter.
Flail mower gearbox oil	75W90	0.14 L	Replace every 300 hours
Hydraulic oil	5W50	6.5 L	Replace after the first 100 working hours and every 400 hours thereafter

## 19. STORAGE AND PROLONGED INACTIVITY

Store the machine in a dry place, protected from the elements. Clean the machine from soil and grass residues and if possible cover it with a tarpaulin when the engine is cold. If the machine is not to be used for an extended period of time (more than 1 month), proceed as follows:

- Disconnect the battery with the battery cut-off switch;
- Lubricate all the joints according to the indicated points.

## 20. TOWING THE MACHINE WITH THE ENGINE OFF

To move the machine with the engine switched off, it is necessary to loosen the screw on the hydrostatic pump (fig. 44/A); use a 16 mm - 5/8" spanner. Loosen the screw by a maximum of two turns.

**⚠ CAUTION:** in this way the effectiveness of the braking device is invalidated.

**🔧 IMPORTANT:** tow the machine at very low speed and for short distances, 100 m maximum, to avoid damaging the hydraulic pump and the motor. To restore correct operation of the machine, remember to tighten the screw again, with a maximum torque of 14 Nm.

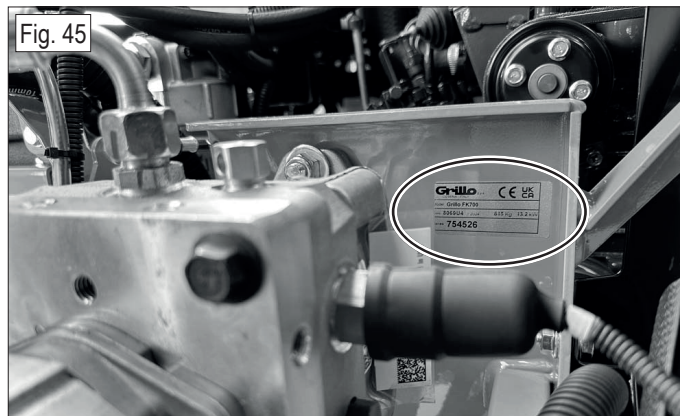
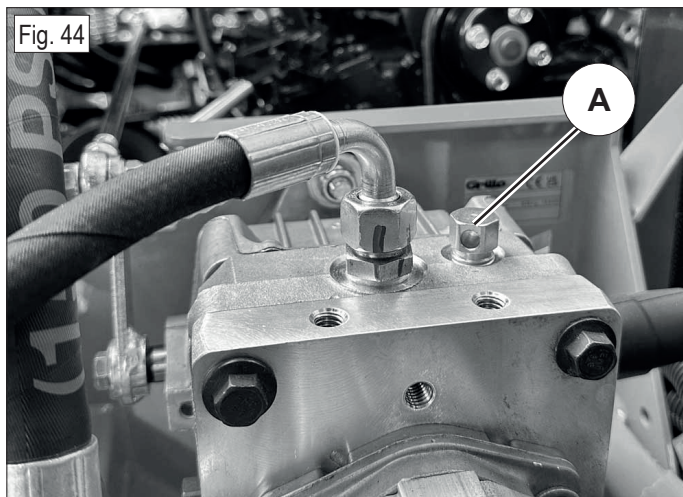

We advise the customer to note down this additional information in the spaces below. It may be useful for the service department.

PURCHASE DATE .....

GRILLO DEALER .....

## 21.3 SPARE PARTS

It is recommended to use only genuine spare parts, which are the only ones that provide safety and interchangeability.

## 21.4 WARRANTY

The warranty is provided in the manner and within the limits specified by current law. The retailer must hand over the machine's warranty certificate to the end customer, printing a copy of the registration from the Grillo website. Transport, servicing and wear parts remain at customer's expense. Any tampering or improper use not specifically authorised by Grillo will invalidate the warranty.

The engine follows the conditions specified by its manufacturer.

## 21.5 HOW TO ORDER SPARE PARTS

Contact our authorised centres.

Please indicate the serial number of the machine and the code of the component to be replaced.

It is possible to identify the part number by consulting the Grillo website: the spare parts tables for the machine will be available by entering the serial number.

## 21. TECHNICAL ASSISTANCE SERVICE

### 21.1 ASSISTANCE

This manual provides instructions for the use of the machine and for its routine maintenance.

**For extraordinary maintenance, for all operations requiring technical skills and expertise, please contact your authorised Grillo dealer.**

### 21.2 IDENTIFICATION DATA

If it is necessary to contact an authorised service centre, for maintenance information, always provide:

machine model .....

serial number .....

The machine's serial number plate is located on the inside of the frame, opposite the hydraulic pump (fig. 45).

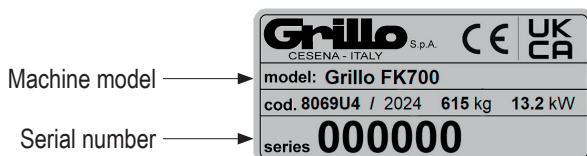

## 22. TRANSPORT WARNINGS

### TOWING HITCH

This machine can be used for towing only occasionally and with certain limitations.

The towing hitch is a service to be used occasionally and consciously, therefore the following limitations must be observed:

- Weight of the towed mass (on wheels) less than 50% of the machine weight;
- Non-continuous towing (max 300 m without stopping) on a plain or light slope (max 10%).



**IMPORTANT: use beyond the limits may impair or cause serious damage to the hydrostatic transmission.**

### LIFTING AND TRANSPORT

If the machine is to be transported on a truck or trailer, lower the flail mower, apply the parking brake and secure it to the means of transport using ropes, cables or chains at the points indicated by the arrow (fig. 46). When lifting, the ropes can be hitched at the point indicated by the arrow (fig. 47). Check that the crane, hoists and ropes have sufficient lifting capacity. The total weight of the machine is 615 kg.

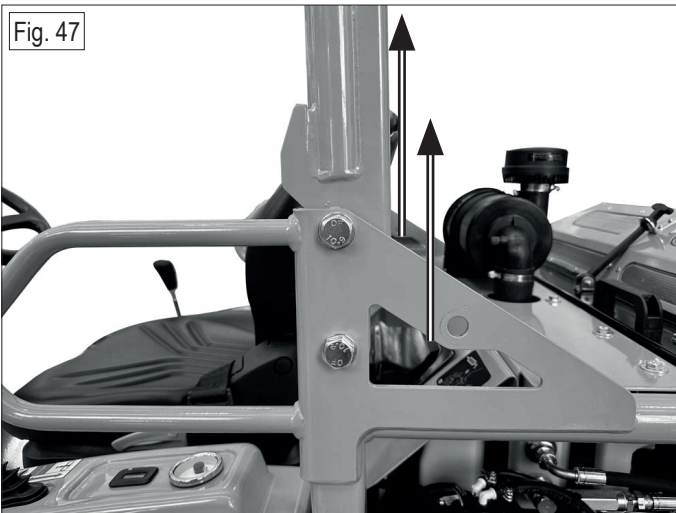
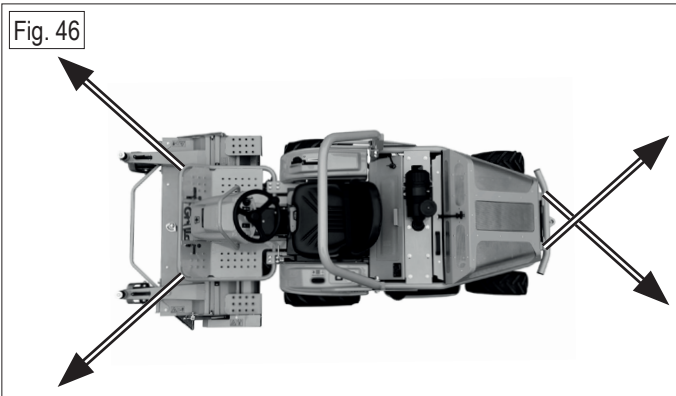

## 23. DISPOSAL

Waste products such as waste oil or fuel, used lubricants, filters, batteries or other such consumable parts can cause harm to people, animals and the environment. They must therefore be disposed of properly. Contact a recycling centre or your retailer for information on proper disposal.



Grillo S.p.A. Via Cervese 1701- 47521 Cesena (FC)- Italy  
www.grillospa.it - E-mail: grillo@grillospa.it



**DECLARATION OF CONFORMITY / DICHIARAZIONE DI CONFORMITÀ  
/ DÉCLARATION DE CONFORMITÉ / KONFORMITÄTSEKLRÄRUNG / DECLARACIÓN DE CONFORMIDAD**

The undersigned / lo sottoscritto / Je soussigné / Der Unterzeichner / Yo suscrito

Ing. Andrea Pinza

as legal representative of: / in qualità di legale rappresentante della ditta: / en qualité de représentant légal de la société: / als rechtlicher Vertreter der Firma: / en calidad de representante legal de la empresa:

GRILLO SPA – Via Cervese, 1701 – 47521 CESENA (FC) – ITALY

declare that the following machinery: / dichiaro che la macchina di seguito indicata: / déclare que la machine suivante: / Hiermit erkläre ich, dass folgende Maschine: / declara que la siguiente máquina:

Model Modello Modèle Modell Modelo	Function Funzione Dénomination Bezeichnung Función	From serial number Dal numero di serie Du numéro de série Ab Seriennummer Desde número de serie
FK 700	Lawnmower / Rasaerba / Tondeuse / Rasenmäher / Cortacésped	754526

fulfils all the relevant provisions of the following directives: / è conforme a tutte le disposizioni pertinenti delle seguenti direttive: / satisfait à l'ensemble des dispositions pertinentes des directives suivantes: / allen einschlägigen Bestimmungen folgender Richtlinien entspricht: / cumple todas las disposiciones pertinentes de las siguientes directivas:

CE		UK CA	
2006/42/CE 2000/14/CE 2014/30/UE	UNI EN ISO 5395	S.I. 2008 No. 1597 S.I. 2001 No. 1701 S.I. 2016 No. 1091	EN ISO 5395

Sound power level / Potenza sonora / Niveaux sonores / Schalleistung / Potencia acústica

Model Modello Modèle Modell Modelo	Cutting width Larghezza di taglio Largeur de coupe Schnittbreite Ancho de corte	Measured sound power level Potenza sonora misurata Puissance sonore mesurée Gemessene Schalleistung Potencia acústica mesurada	Guaranteed sound power level Potenza sonora garantita Puissance sonore garantie Garantierte Schalleistung Potencia acústica garantizada	Uncertainty Incertezza Incertitude Unsicherheit Incertidumbre
FK 700	115 cm	99 dBA	100 dBA	1 dBA

Values determined according to / Valori determinati in accordo a / Niveaux sonores selon / Werte bestimmt gemäß / Valores determinados conforme a  
2000/14/CE - VI.1

Measure sound pressure at the operator's ear / Pressione sonora misurata all'orecchio dell'operatore /  
Niveaux sonores au niveau des oreilles de l'utilisateur / Gemessener Schalldruck am Ohr des Nutzers / Presión acústica medida a la oreja del usuario

Model Modello Modèle Modell Modelo	Sound pressure Pressione sonora Niveau sonore Schalldruck Presión acústica	Uncertainty Incertezza Incertitude Unsicherheit Incertidumbre
FK 700	91 dBA	1 dBA

Vibrations / Vibrazioni / Vibrations / Schwingungen / Vibraciones

Model Modello Modèle Modell Modelo	Whole body Corpo intero Au corps entier Gesamter Körper Cuerpo entero	Uncertainty Incertezza Incertitude Unsicherheit Incertidumbre	Hand/arm Mano/braccio Main/bras Hand/Arm Mano/brazo	Uncertainty Incertezza Incertitude Unsicherheit Incertidumbre
FK 700	0.72 m/s <sup>2</sup>	0.5 m/s <sup>2</sup>	1.42 m/s <sup>2</sup>	0.5 m/s <sup>2</sup>

Juridical person authorised to compile the technical file: / Persona giuridica autorizzata a costituire il fascicolo tecnico: / Personne morale autorisée à constituer le dossier technique: / Juristische Person, die bevollmächtigt ist, die technischen Unterlagen zu erstellen: / Persona juridica facultada para elaborar el expediente técnico:

GRILLO SPA – Via Cervese, 1701 – 47521 CESENA (FC) – ITALY

Person empowered to draw up the declaration on behalf of the manufacturer: / Persona autorizzata a redigere la dichiarazione a nome del fabbricante: / Personne ayant reçu pouvoir pour rédiger cette déclaration au nom du fabricant: / Ermächtigte Person zur Ausfertigung der Erklärung im Namen des Herstellers: / Persona apoderada para redactar esta declaración en nombre del fabricante:

Ing. Andrea Pinza

GRILLO SPA – Via Cervese, 1701 – 47521 CESENA (FC) – ITALY

Managing Director / Amministratore Delegato / Directeur Général / Stellvertretender Geschäftsführer / Director Adjunto

**Grillo** S.p.A.

Ing. Andrea Pinza -

*Andrea Pinza*

Cesena, 28/05/2024

The spare parts catalogues are available on line at [http://www.grilloagrigarden.co.uk/spare\\_parts\\_lists](http://www.grilloagrigarden.co.uk/spare_parts_lists)  
Le tavole ricambi sono disponibili online all'indirizzo [http://www.grillospa.it/tavole\\_ricambi](http://www.grillospa.it/tavole_ricambi)  
Les vues éclatées son disponibles en ligne sur [http://www.grillofrance.fr/vues\\_eclatees](http://www.grillofrance.fr/vues_eclatees)  
Die Ersatzteillisten sind online verfügbar unter <http://www.grillodeutschland.de/ersatzteillisten>  
Los despieces son disponibles on line en <http://es.grillospa.it/despieces>

**Grillo S.p.A.**

VIA CERVESE 1701 - 47521 CESENA - ITALIA  
Tel: (+ 39) 0547633111  
Website: [www.grillospa.it](http://www.grillospa.it)  
E-mail: [grillo@grillospa.it](mailto:grillo@grillospa.it)

**Grillo Agrigarden Ltd**

DOVE FIELDS UTTOEXETER - ST148HU STAFFORDSHIRE - UNITED KINGDOM  
Tel: (+ 44) 01889569149  
Website: [www.grilloagrigarden.co.uk](http://www.grilloagrigarden.co.uk)  
E-mail: [info@grilloagrigarden.co.uk](mailto:info@grilloagrigarden.co.uk)

**Grillo Australasia Pty Ltd**

14 REBECCA COURT - VIC 3943 SORRENTO - AUSTRALIA  
Tel: (+ 61) 0428206225  
Website: [www.grilloaustralia.com.au](http://www.grilloaustralia.com.au)  
E-mail: [allan@grilloaustralia.com.au](mailto:allan@grilloaustralia.com.au)

**Grillo Deutschland GmbH**

GUNTERSRIETHER STR.14 - 91224 HARTMANNSHOF - DEUTSCHLAND  
Tel: (+ 49) 09154949216  
Webseite: [www.grillodeutschland.de](http://www.grillodeutschland.de)  
E-Mail: [grillo@grillodeutschland.de](mailto:grillo@grillodeutschland.de)



**Grillo**  
AGRIGARDEN MACHINES